

徐工徐工 助您成功
XCMG FOR YOUR SUCCESS



XGC320 履带起重机

CRAWLER CRANE



地址(Add): 中国江苏省徐州市金山桥经济开发区桃山路19号 邮编(Postal Code): 221004
No.19 Taoshan Road, Economic development zone of jinshanqiao,Xuzhou,Jiangsu Province,China
统一服务热线(Unified service hotline): 86 400-110-9999

销售热线Sales Hotline	服务热线Service Hotline
销售电话(Sale Tel): 86 0516-87892094	服务电话(Service Tel): 86 400-001-5678
销售传真(Sale Fax): 86 0516-87892074	服务传真(Service Fax): 86 0516-87892080
电子邮件(E-mail): jjyxd@xcmg.com	备件电话(Service Tel): 86 0516-87892086
服务质量投诉电话 (Quality Supervision Tel): 86 0516-87892587	备件传真(Service Fax): 86 0516-87892083



欢迎访问徐工商城
省心更省钱一站式



欢迎关注徐工履带起重机官方微信
1. 直接扫码“XCMG_xgj”增加好友
2. 查找公众账号“徐工履带起重机”
3. 直接扫描上方二维码

—2021年01月版—

注: 出于产品不断改进的需要, 我们保留对产品型号、参数、配置进行变更的权力, 恕不另行通知。



CONTENTS

目录

P02

- Technical features
- Product introduction
- Safety Devices

P10

- Main parameters
- Typical Working Conditions
- Light boom working condition
- Tower jib working condition
- Main components

02

XGC320 Crawler Crane

P03-P04 Technical features

P05-P07 Product introduction

P08-P09 Safety Devices

01 Strong and excellent lifting capacity

- Max. rated lifting capacity 320t, max. load moment 1870t.m. There are 9 operating modes in 3 working conditions, including boom working condition, light boom working condition, tower jib working condition. The lifting capacity for medium and long boom with medium or small radius is particularly strong. It is excellent in quality and reasonable in price.
- Max. boom length is 88m, max. light boom length is 107.5m, max. tower jib length is 60m, max. Each boom combination can be equipped with single pulley, with strong adaptability to working conditions. Super-long boom and jib combination provides higher lifting height and wider working range. Make sure the crane is fully used.

02 Reliable and advanced safety security

- The chassis is large with low center of gravity, the key structural parts are welded with high strength material, the modular components are universally used, all these are designed to ensure the firmness and stability of the basic machine.
- The large-diameter slewing bearing is with elliptical track and big ball, the bearing capacity is improved by 30%; the slewing bearing is stable and reliable in quality, and the service life is doubled.
- Lattice boom is made up of high strength steel pipe, with large cross section, big pipe diameter and thin wall thickness, combined with single/double center hitch and cross-winded wire rope, the operation capacity is maximized.
- Modularized winch structure with large torque, high tensile strength wire rope with large single line pull and less parts of line, the working efficiency is very high.
- Large volume hydraulic oil tank and aluminum oil radiator, the oil temperature rises slowly with good heat dissipation effect, which effectively extends the service life of hydraulic seals.
- Large capacity diesel tank and optional fuel tank, with sufficient oil reserve, long standby time, less refueling times and short auxiliary time.
- Large-power engine, complied with European Off-highway Tier V Emission Standard, strong power reserve, environment friendly and energy saving. Pre-heater is equipped for the operation in the temperature below -20°C.
- Hirschmann LMI control system, with lightning protection and anti-interference function, it can be used for sustainable high-intensity work in harsh environment.
- Hydraulic pump, motor, main valve and other key components used for this crane are with well-known brands at home and abroad, which can guarantee the reliable operation of the system.
- The motor speed is directly adjusted by main pump, with less heat and gentle action. The system is stable, simple and reliable.
- Self-lubrication and maintenance-free track roller, wear-resistant nylon pulley and humanized walkway make the crane more perfect.

03 Barrier-free transport all around the world

- To meet the requirements of road laws and regulations in the world, after disassembly, the maximal weight of a single unit in transport state is 36.2t, the transport width is 3.0m and the height is 3.3m. This meets stringent transport standards of road, it not only make the customers free from the trouble of higher transport standards in future, but also reduce the cost of operation and site transfer.
- Modular transport concept is adopted, which not only include transporting pendant with boom and jib sections, and pushing boom insert, tower jib insert and fixed jib insert into each other for transportation, but also include the integrated transportation of tower jib triplet .

04 Convenient and efficient disassembly

- Self-assembly and disassembly of counterweight, optimized counterweight, the counterweight block is small in size and less in quantity, less lifting times and easy installation.
- Safe and reliable mast raising mechanism, the mast can be raised and lowered quickly and conveniently, short assembly/disassembly time and high working efficiency.
- Use mast crane to realize the assembly and disassembly of crawler track, the connection and disconnection of boom and jib, and the hoisting of small pieces.
- Main parts of the crane (for example: car-body and track beam, boom and turntable) are connected with power pin, easy disassembly and low labor intensity.
- This crane (with boom) can be lifted as whole, which is suitable for conditions with difficult disassembly and inconvenient travel operation, especially for the transfer between different ships at sea.

05 Elaborate integration of structural parts

- To reduce purchasing cost of the crane, the functions of crane parts is integrated and optimized reasonably after careful investigation of the part use frequency. For example, the auxiliary hoist winch can be used as jib luffing winch in tower jib working condition; boom connection section can be used in boom, tower jib, fixed jib and TBM jib working conditions; boom tapered section can be used in boom and light boom working condition; tower jib top and tower jib insert can be used as light boom sections; boom pendant, tower jib pendant and fixed jib pendant are generally integrated.

06 Beautiful and comfortable operator' s cab

- Fully closed operator' cab is designed according to ergonomic principle, with XCMG features, smooth appearance and broad vision, it is beautiful and comfortable.
- The operator' cab is equipped with tempered safety glass, intermittent wiper and cleaning nozzle, sun shade curtain, rubber pad, headrest, armrest, adjustable seat, air conditioning and so on.

07 Wide application

- It belongs to middle tonnage crawler crane, which is widely used in the following fields:
 - (1) Traffic infrastructure construction: subway, high-speed train, road, bridge.
 - (2) Urban building construction: municipal work, stadium, building and factory.
 - (3) Energy equipment installation: petrochemical work, oil refining, metallurgy, coal.
 - (4) Heavy lifting and transportation: port, ship port, wharf, steel structure.
 - (5) Power construction industry: wind power, nuclear power, thermal power and hydropower.

08 Customized working conditions

- It meets the specific requirements of small radius, high position and large lifting capacity. It can be used for the lifting of tower, tank, kettle, vessel, pipeline and etc. in petrochemical industry; as well as the lifting of some wind power equipments. For example, in 88m main boom working condition, the working radius is 11m, the lifting capacity is 97.9t, and the lifting height is 84m.
- Long boom configuration in tower jib working condition meets the construction demand of steel structure workshop, tower jib single top working condition is optionally configured to improve the working efficiency. For example, in H55+WS42 tower jib working condition, the load capacity of tower jib main hook is 56.2, the load capacity of tower jib single top the third hook is 16t.
- Without purchasing any other parts, light boom working condition is realized only buying tower jib, which can significantly improve the lifting height of the load and expand the coverage range. The maximum light boom length is 107.5m, radius 14m, the lifting capacity is 51.7t.
- Fully considering the cost of the crane and site transfer, the performance tables based on different turntable counterweight combinations are provided to enrich the working conditions for users. For example: to meet the requirements of port, shipyard and trestle construction, give full play to the crane' s travel-with-load ability and to reduce fuel consumption, 95t turntable counterweight and 40t car-body counterweight can be used for lower ground pressure and less damage to road surface.

Product introduction

Boom combination

Boom length 22m ~88m (standard configuration: 64m); boom composition: boom base 10.5m×1, transitional section 7m×1, connection section 1.5m×1, boom insert 3m×1, boom insert 6m×1, boom insert 12m×3, boom insert 12m×2 (optional configuration), and one 260t boom head sheave block (optional configuration). Main boom can be equipped with single top unit. Tower jib length 24m ~ 60m (standard configuration: 42m), tower jib composition: jib base 9m×1, jib insert 6m×1, jib top 9m×1, jib insert 6m×2 (standard configuration: 1 piece), jib insert 12m×2 (standard configuration: 1 piece), front strut 9m×1, rear strut 9m×1. Tower jib is optionally configured with tower jib single top. Light boom length 65.5m ~ 107.5m (standard configuration: 95.5m), light boom is the combination of boom sections and tower jib sections, light boom is optionally configured with single top unit.

Boom luffing components

Boom luffing component is made of high-strength pendant structure, with high safety factor. Pendant transition adopts balance beam structure with uniform stress. "Peach" -shaped connecting hole, the assembly is convenient, labor- saving and efficient.

Mast

Mast is a box-type two-limb structure, with strengthened beam between two limbs for good stability. Mast raising cylinder can rotate around connection pivot of turntable, to realize mast erection, raising and lowering.

Turntable

Turntable is a key load bearing structural component to connect crane superstructure and crane undercarriage, use of high-strength steel plate welded in "I" box-type composite box beam structure on both sides, coupled with undercarriage through slewing ring, with good overall strength and stability. Cab, main luffing winch, engine system, main pump, hydraulic valve, cabinet, mast, boom base section and superstructure counterweight are respectively connected with different parts of the turntable.

Mechanism composition

Main hoist winch I	HB/1, HBS/1, LB/1, LBS/1, HW/1, HWS/1, HF/1, HBF/1, TBF/1 and TBF, used for main hook block	At the lower part of boom base section, near the middle part
Main hoist winch II	HWS/3, used for the third hook block	At the lower part of boom base section, near the root (optional)
Auxiliary hoist winch	(1)HBS/2, LBS/2, HBF/2, TBF/2 and TBF, used for auxiliary hook block. (2)Used for tower jib elevation in tower jib working condition.	At the lower part of boom base section, near the front part
Main luffing winch	Boom luffing operation	At the middle and rear of turntable
Slewing unit	Superstructure slewing	At the front of turntable, left side
Travel unit	Crane travel	Crawler drive roller

Crane mechanism and configuration refer to the table below.

Hoist winch

Hoist winch includes main hoist winch I, aux. hoist winch and main hoist winch II (optional), planetary reducer is driven by motor, to achieve main or auxiliary hook block hoisting up/down through drum and luffing pulley block. The hoist winch has built-in planetary reducer, with constant closed brake, to achieve "spring braking/hydraulic release" function, safe and reliable. The anti-rotation wire rope used for main hoist winch I is left-handed rotation and twist in the same direction, rope diameter $\phi 28\text{mm}$, rope length 680m; The anti-rotation wire rope used for aux. winch is left-handed rotation and twist in the same direction, rope diameter $\phi 26\text{mm}$, rope length 300m; The anti-rotation wire rope used for main hoist winch II (optional) is left-handed rotation and twist in the same direction, rope diameter $\phi 28\text{mm}$, rope length 360m.

Luffing winch

Luffing winch includes main luffing winch and tower jib luffing winch. For main luffing winch, planetary reducer is driven by motor to achieve boom luffing through drum and luffing pulley block. Main luffing winch has built-in planetary reducer, with constant closed brake, to achieve "spring braking/hydraulic release" function, safe and reliable. Main luffing winch drum has a ratchet pawl locking device, and driven by a hydraulic cylinder, to achieve multi-lock protection. Wire rope used for main luffing winch is left-handed rotation and twist in the same direction, without rotation resistance function, rope diameter $\phi 26\text{mm}$, rope length 360m. Tower jib luffing winch is the same device as the auxiliary hoist winch, through the function switch-over to achieve tower jib luffing.

Slewing unit

Slewing unit and slewing ring is driven by external meshing of gear, arranged in front of turntable, a planetary reducer is driven by motor to drive the slewing ring to achieve 360° rotation. Slewing unit has a built-in planetary reducer, with constant closed brake design to achieve "spring braking/hydraulic release" function, to ensure the slewing mechanism a high safety brake. Slewing unit also has a mechanical locking device for locking protection of the slewing unit. Slewing unit also has a free-swing function.

Slewing ring

Strengthened slewing ring with elliptical track, it has the features of large load bearing capacity, small slewing resistance, wearing resistance, and longer service life.

Cylinder assy.

The connection of boom and turntable, car-body and track frame, counterweight tray and turntable, is realized by power pinning driven by cylinder. Mast raising cylinder, outrigger cylinder, crawler tension cylinder, all these allow the machine assembly/disassembly quicker and easier. Operator' s cab also has a cylinder for vertical tilting and horizontal rotation.

Operator' s cab

Fully closed operator' cab is designed according to ergonomic principle, with XCMG features, gorgeous appearance and broad vision; it is comfortable and convenient to operate.

Car-body

Car-body is a box-type radial structure, welded by high strength steel plates with good overall rigidity and high strength.

Crawler travel unit

Crawler travel unit is divided into left/right crawler, consisting track frame, track shoe, track roller, drive sprocket, guide roller, carrier roller, travel device and tension device. Track frame: symmetrically arranged, one for each side, made of high-strength steel plate welded in box-type structure, and a parallel iron is set for car-body installation positioning to play a role of guide and wear. Drive roller: Drive roller assy. is connected on planetary reducer housing with high-strength bolts. Track roller: double-flange design, with built-in floating seals, self-lubrication. Tension roller: The rollers are used to adjust crawler tension level through hydraulic cylinder and adjusting pads. Carrier roller: The rollers have built-in floating seals, self lubrication. Track shoe: installed on crawler tracks. Travel unit: constant closed planetary gear reducer with strong travel power and high flexibility and mobility. It is multiple wet-type constant closed brake, spring brake, and hydraulic release.

Product introduction

Notes on working conditions

For this crane, there are 9 working conditions according to different hoist mechanisms, working equipments, hooks and boom positions.

Boom working condition 【HB (S)】	HB/1	Use boom main hook to lift the load, no boom single top
	HBS/1	Use boom main hook to lift the load, with aux. hook installed on boom single top
	HBS/2	Use aux. hook of boom single top to lift the load, with main hook installed on boom
Light boom working condition 【LB (S)】	LB/1	Use main hook of light boom to lift the load, no boom single top
	LBS/1	Use main hook of light boom to lift the load, with aux. hook installed on boom single top
	LBS/2	Use the aux. hook of boom single top to lift the load, with main hook installed on light boom
Tower jib working condition 【HW(S)】	HW/1	Use main hook of tower jib for lifting operation, no boom pulley block and tower jib single top
	HWS/3	Use the third hook of tower jib single top to lift the load, with tower jib main hook, no boom pulley block
	HWS/1	Use main hook of tower jib to lift the load, with the third hook of tower jib single top, no boom pulley block

Note: For working condition codes, “/1” means using main hoist winch I; “/2” means using aux. hoist winch; “/3” means using main hoist winch II.

Hydraulic system

The use of hydraulic proportional pilot control system can achieve the flow distribution that is independent from the load, with accurate speed, sensitive operation and good fine motion. The main valve can achieve combined operation of lots movement, featuring compact structure, and easy maintenance.

Main hoist and auxiliary hoist winches have double pump confluence, easy to achieve winch high/low speed control. Specialized slewing buffer circuit design, slewing start and stop is smooth and soft, to meet the requirements of fine lifting operation.

Electrical system

Electrical system mainly includes the following components: engine control, auxiliary equipment, hydraulic system control, load moment limiter, safety monitors and data display. Electrical system composition: conventional electrical system and PLC control system. Conventional electrical system includes power supply, start control, cab air conditioner and sound, lights, wipers and so on. PLC control system includes control of main and auxiliary winches, slewing, boom luffing and other movements, engine state monitoring. All the movements are controlled through PLC logic control of CAN-bus technology.

Engine system

Model: Scania DC09 313A
Rated power: 257 kW/2100rpm;
Max. torque/max. speed: 1730Nm/1400rpm;

Emission standard: comply with EURO V standard;
Fuel tank capacity: 700L (1050L is optionally configured)

Counterweight

Counterweight consists of car-body counterweight and turntable counterweight, turntable counterweight is 125t, car-body counterweight is 40t.

Hook block

The commonly used hook block is as the follows:

Hook name	200t	160t	16t
Weight (t)	4.2	3.9	0.9

In case of special needs, the contract shall specify the provisions of 300t, 260t, 130t, 100t, 80t, 50t hooks, etc.

Safety Devices

This crane widely uses mechanical, electronic and hydraulic and other safety and warning devices to ensure the safe use of the machine. The safety devices include: load moment limiter, slewing lock device, boom backstop device, hoist limit switch, boom angle limiter, level gauge, slewing warning and hydraulic system relief valve, balance valve, hydraulic lock, and etc.

Assembly mode & Working mode exchange switch

Exchange between assembly mode and working mode is realized. In Assembly mode, over-wind protection device, boom angle limiter and load moment limiter are all out of service, in order to facilitate crane assembly. In working mode, all safety devices do work.

Emergency stop button

In emergency conditions, press this button to stop all crane movements.

Anti-operation error function

The handle is to prevent mis-operation. There is a safety protection switch, all movement signals are shielded when this switch is pressed, and the handle is disabled to prevent operation error.

Winch over-wind protection device

There is an over-wind device on boom head to prevent rope from being over-wound. When main/auxiliary winch hoists up to a certain lifting height, the over-wound warning lamp on instrument panel lights up, at the same time, load moment limiter stops crane hoisting up movements.

Winch over-release protection device

An encoder is set on hoist winches as rope end limiter to prevent wire rope from over-releasing. When there are only three loops of rope left, the over-release warning lamp on instrument panel lights up, at the same time, the movement of lowering down is stopped.

Ratchet locking device

It is used to lock the luffing winch so that boom is stopped and placed safely at non-working state.

Slewing locking device

Slewing locking device is used for superstructure slewing locking when stopping the crane.

Backstop device

The crane is equipped with boom and jib strut backstop devices to prevent boom and strut backward tilting.

Boom angle limit

When boom is raised to a specified angle, the boom raising is stopped by both control of load moment limiter and hoist limit switch. When boom luffing angle is less than the specified angle, boom lowering is stopped by control of load moment limiter and which also gives a sound warning.

Hook latch

All hook blocks are equipped with hook latch to prevent the hanging rope on the hook head from falling.

Hydraulic system safety protection device

Hydraulic system is equipped with hydraulic balance valve, hydraulic relief valve and other devices to ensure the stable and safe work for the system.

LMI system

LMI can detect boom angle and lifting load automatically. It has pre-warning and overload automatic stopping function.

Audio/video warning

The tri-color light and audio/video warning can show crane loading and operation state to give the operator and staff outside warning.

Illuminator lamp

The illuminator lamp is in front of turntable, on the top of and inside operator's cab for lighting.

Rearview mirror

It is located outside the operator's cab for the driver easy to observe the situation behind the machine.

Height mark lamp

It is located on boom tip for high level operation warning.

Anemometer

It can detect the current wind speed and send signal to the monitor in operator's cab to remind the operator for safe operation in wind load.

Level gauge

Level gauge is equipped to display the ground gradient, so as to provide crane levelness for the operator.

10

XGC320 Crawler Crane

P11-P12 Main parameters

P13-P22 Typical Working Conditions

P23-P30 Light boom working condition

P31-P48 Tower jib working condition

P49-P57 Main components

Outline Dimensions

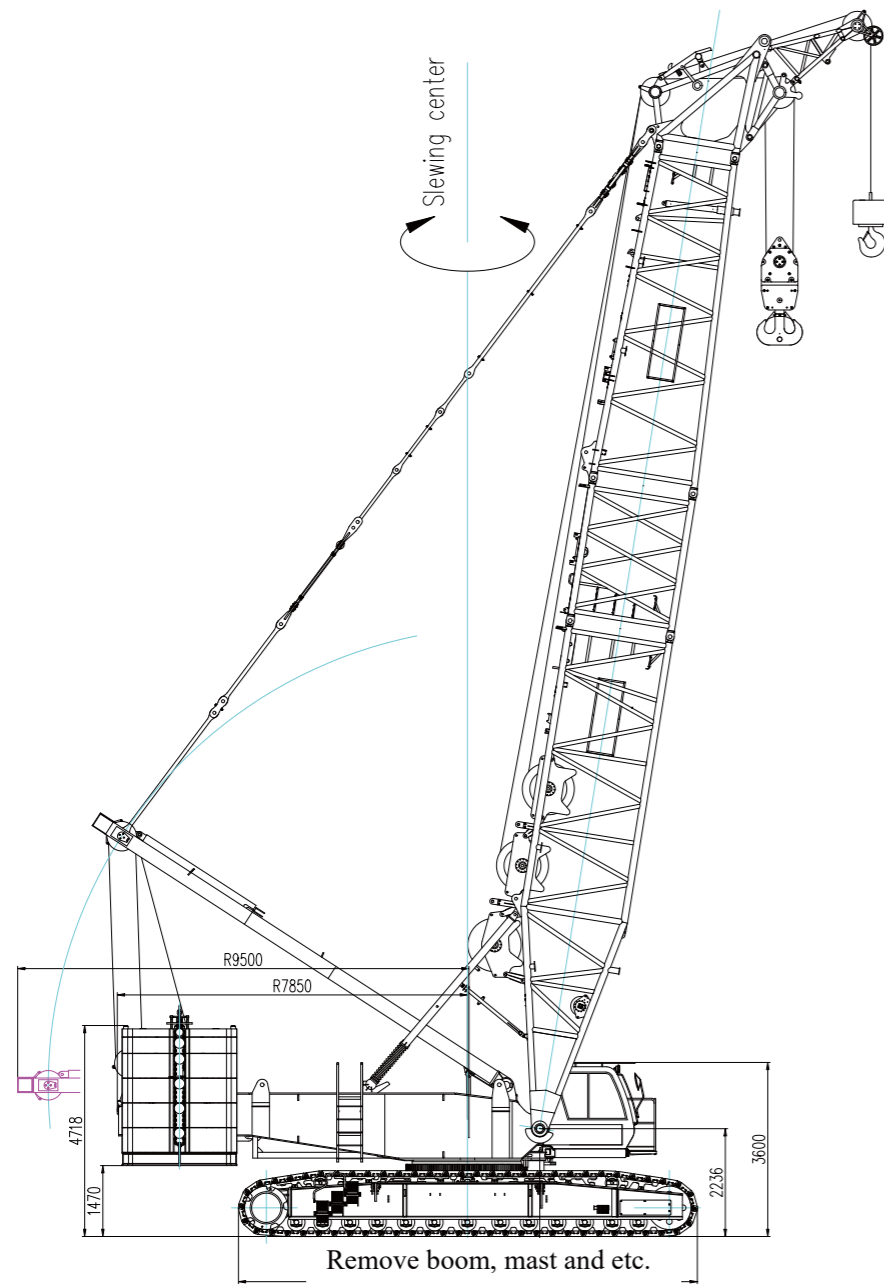

Remove boom, mast and etc.

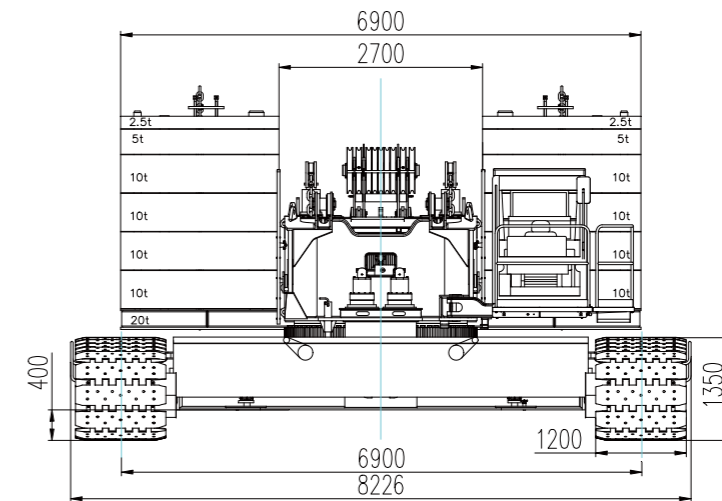

XGC320 crawler crane outline dimension

Items		Unit	Data
Max. rated lifting capacity	Boom working condition	t	320
	Light boom working condition	t	118
	Tower jib working condition	t	130
Max. load moment		t.m	1870
Dimensions	Boom length	m	22 ~ 88
	Light boom length	m	65.5 ~ 107.5
	Tower jib length	m	24 ~ 60
Speed	Hoist winch max. single line speed	m/min	120
	Boom luffing winch max. single line speed	m/min	2×42
	Tower jib luffing winch max. single line speed	m/min	120
	Max. slewing speed	r/min	0.8
Engine	Max. travel speed	km/h	1.0
	Engine rated output and speed	kW	252 (Optional 257)
	Emission standard	-	EURO V
Total mass (22m boom, 200t hook block, counterweight 95t+40t)		t	260
Mean ground pressure		MPa	0.143
Grade-ability		-	30%
Max. mass of single unit in transport state		t	36.2
Max. dimension of single unit in transport state(L×W×H)		m	11.12×3.00×3.30
Hook block configuration		t	200, 160, 16

Note:

1. Single line speed is the calculated value of the rope on the drum most outside layer with engine idle running, which changes according to different load and working conditions.
2. Travel speed and slewing speed is the theoretical value for the crane based on level and solid ground.
3. The data in this table is full boom configuration based on 125t turntable counterweight and 40t car-body counterweight.
4. We reserve the right to improve and update the technical specifications without prior notice.

Typical Working Conditions

Boom working condition

A. Boom combinations in boom working condition without boom single top

Name & Number Boom combination	Boom base 10.5m	Boom insert 3m	Boom insert 6m	Boom insert 12mA	Boom insert 12mB	Boom tapered section 7m	Boom connection section 1.5m	260t boom head sheave block
HB22	1	1	0	0	0	1	1	1
HB25	1	0	1	0	0	1	1	1
HB28	1	1	1	0	0	1	1	1
HB31	1	0	0	1	0	1	1	1
HB34	1	1	0	1	0	1	1	1
HB37	1	0	1	1	0	1	1	1
HB40	1	1	1	1	0	1	1	1
HB43	1	0	1	2	0	1	1	1
HB46	1	1	0	2	0	1	1	1
HB49	1	0	1	2	0	1	1	1
HB52	1	1	1	2	0	1	1	1
HB55	1	0	0	3	0	1	1	1
HB58	1	1	0	3	0	1	1	1
HB61	1	0	1	3	0	1	1	1
HB64	1	1	1	3	0	1	1	1
HB67	1	0	0	3	1	1	1	1
HB70	1	1	0	3	1	1	1	1
HB73	1	0	1	3	1	1	1	1
HB76	1	1	1	3	1	1	1	1
*HB79	1	0	1	3	2	1	1	1
*HB82	1	1	0	3	2	1	1	1
*HB85	1	0	1	3	2	1	1	1
*HB88	1	1	1	3	2	1	1	1

Notes:

1. "*" Boom length needs to use 1.33m center hitch.
2. For boom sections, tower jib rear pendant needs to be removed; for boom tapered section, tower jib guide pulley needs to be removed.

B. Boom combinations in boom working condition with boom single top

Name & Number Boom combination	Boom base 10.5m	Boom insert 3m	Boom insert 6m	Boom insert 12mA	Boom insert 12mB	Boom tapered section 7m	Boom connection section 1.5m	260t boom head sheave block	Boom single top S
HBS25	1	0	1	0	0	1	1	1	1
HBS28	1	1	1	0	0	1	1	1	1
HBS31	1	0	0	1	0	1	1	1	1
HBS34	1	1	0	1	0	1	1	1	1
HBS37	1	0	1	1	0	1	1	1	1
HBS40	1	1	1	1	0	1	1	1	1
HBS43	1	0	1	2	0	1	1	1	1
HBS46	1	1	0	2	0	1	1	1	1
HBS49	1	0	1	2	0	1	1	1	1
HBS52	1	1	1	2	0	1	1	1	1
HBS55	1	0	0	3	0	1	1	1	1
HBS58	1	1	0	3	0	1	1	1	1
HBS61	1	0	1	3	0	1	1	1	1
HBS64	1	1	1	3	0	1	1	1	1
HBS67	1	0	0	3	1	1	1	1	1
HBS70	1	1	0	3	1	1	1	1	1
HBS73	1	0	1	3	1	1	1	1	1
HBS76	1	1	1	3	1	1	1	1	1
*HBS79	1	0	1	3	2	1	1	1	1
*HBS82	1	1	0	3	2	1	1	1	1
*HBS85	1	0	1	3	2	1	1	1	1
*HBS88	1	1	1	3	2	1	1	1	1

Notes:

1. "*" Boom length needs to use 1.33m center hitch.
2. For boom sections, tower jib rear pendant needs to be removed; for boom tapered section, tower jib guide pulley needs to be removed.

C. Boom raising table in boom working condition

Boom raising table in boom working condition without boom single top (HB/1)

HB/1 Boom combination	Counterweight combination: turntable counterweight (t)+car-body counterweight (t)			
	125+40	115+40	105+40	95+40
HB22	○	○	○	○
HB25	○	○	○	○
HB28	○	○	○	○
HB31	○	○	○	○
HB34	○	○	○	○
HB37	○	○	○	○
HB40	○	○	○	○
HB43	○	○	○	○
HB46	○	○	○	○
HB49	○	○	○	○
HB52	○	○	○	○
HB55	○	○	○	○
HB58	○	○	○	○
HB61	○	○	○	○
HB64	○	○	○	○
HB67	○	○	○	●
HB70	○	○	●	●
HB73	○	●	●	●
HB76	●	●	●	●
HB79	●	●	●	●
HB82	●	●	●	●
HB85	●	●	●	×
HB88	●	●	×	×

Notes:

1. "○" -- can raise boom; "●" -- wedge required to raise boom; "×" -- cannot raise boom, this working condition cannot be used.
2. For boom raising, position crawler drive sprocket at the rear of the crane.

Boom raising table in boom working condition with boom single top (HBS/1 & HBS/2)

HBS/1 & HBS/2 Boom combination	Counterweight combination: turntable counterweight (t)+car-body counterweight (t)			
	125+40	115+40	105+40	95+40
HBS25	○	○	○	○
HBS28	○	○	○	○
HBS31	○	○	○	○
HBS34	○	○	○	○
HBS37	○	○	○	○
HBS40	○	○	○	○
HBS43	○	○	○	○
HBS46	○	○	○	○
HBS49	○	○	○	○
HBS52	○	○	○	○
HBS55	○	○	○	○
HBS58	○	○	○	○
HBS61	○	○	○	○
HBS64	○	○	○	●
HBS67	○	○	●	●
HBS70	○	●	●	●
HBS73	●	●	●	●
HBS76	●	●	●	●
* HBS79	●	●	●	●
* HBS82	●	●	●	×
* HBS85	●	●	×	×
* HBS88	●	×	×	×

Notes:

1. "○" -- can raise boom; "●" -- wedge required to raise boom; "×" -- cannot raise boom, this working condition cannot be used.
2. "*" Boom length needs to use 1.33m center hitch.
3. For boom raising, position crawler drive sprocket at the rear of the crane.

Typical Working Conditions

Boom working condition _ boom main hook (without boom single top, HB/1)

Boom working condition _ boom main hook working range (without boom single top, HB/1)

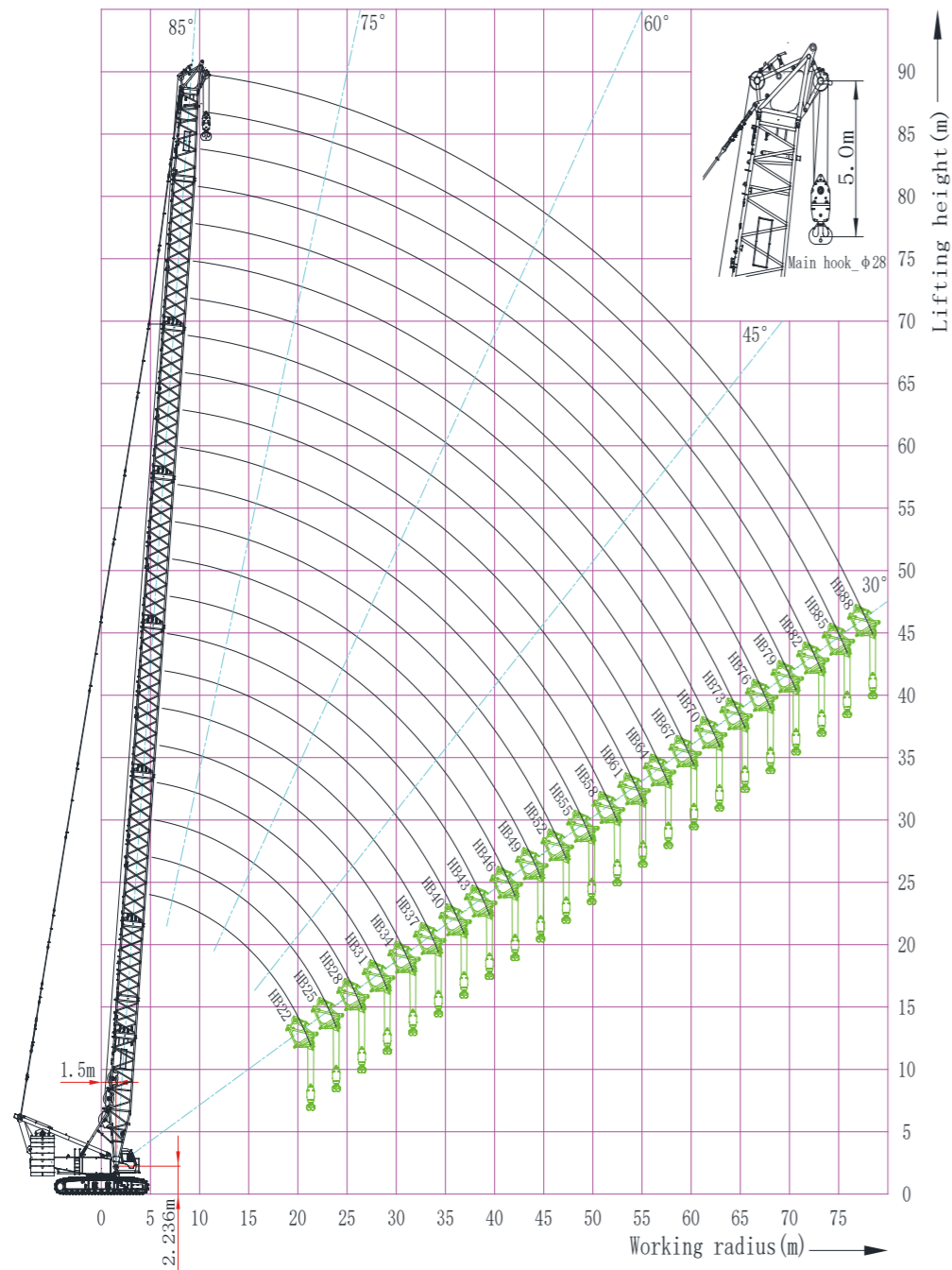

Boom working condition_boom main hook working range (HB/1, without boom single top)

Boom working condition _ boom main hook lifting capacity table in (without boom single top, HB/1_125t+40t)

HB/1 Radius (m)	Boom length (m)											
	22	28	34	40	46	52	58	64	70	76	82	88
	t	t	t	t	t	t	t	t	t	t	t	t
5	320.0▲											
6	300.0▲	284.9▲	252.5▲									
7	254.0▲	252.5▲	251.4★	224.2★								
8	228.3★	222.2★	221.2★	220.5★	209.7	195.0						
9	199.2★	197.7★	197.2★	199.9	196.1	192.4	180.0	164.9				
10	179.1★	182.3	180.4	176.9	173.6	170.5	166.5	160.0	149.5	130.3		
11	170.0	164.6	161.5	158.4	155.5	152.7	150.0	144.5	139.5	128.6	113.4	97.9
12	155.0	148.8	146.0	143.2	140.7	138.1	135.8	131.5	127.2	122.9	112.2	96.8
14	127.7	124.4	122.2	119.9	117.7	115.6	113.5	111.0	107.7	104.3	101.1	94.4
16	105.3	103.1	102.9	102.5	100.8	98.9	97.1	95.3	92.9	90.1	87.5	84.8
18	89.4	87.6	87.4	87.0	86.6	86.0	84.4	82.8	81.4	79.0	76.7	74.4
20	77.4	75.8	75.6	75.2	74.8	74.2	73.7	72.8	71.7	69.9	68.0	65.9
22		66.7	66.5	66.0	65.6	65.0	64.5	63.9	63.6	62.4	60.7	58.8
24		59.2	59.0	58.5	58.1	57.5	57.0	56.4	56.1	55.5	54.6	52.9
26		53.0	52.9	52.5	52.0	51.4	50.9	50.3	50.0	49.3	48.9	47.9
28			47.8	47.4	46.9	46.3	45.8	45.2	44.8	44.2	43.6	43.0
30			43.4	42.9	42.5	41.9	41.3	40.7	40.4	39.7	39.2	38.6
32				39.2	38.8	38.2	37.6	37.0	36.6	36.0	35.5	34.8
34				35.9	35.5	34.9	34.4	33.7	33.4	32.7	32.2	31.5
36				33.1	32.7	32.1	31.5	30.9	30.5	29.8	29.3	28.7
38					30.1	29.5	29.0	28.3	28.0	27.3	26.8	26.0
40					27.9	27.3	26.7	26.0	25.6	24.9	24.5	23.8
42					25.7	25.2	24.6	24.0	23.6	22.9	22.4	21.7
46						21.7	21.1	20.5	20.1	19.4	18.9	18.2
50							18.2	17.6	17.3	16.6	16.1	15.4
52							17.0	16.3	16.0	15.3	14.8	14.1
56								14.1	13.7	13.0	12.5	11.8
58									12.7	12.0	11.5	10.8
60									11.8	11.1	10.6	9.9
68										7.8	7.3	6.6
72											6.0	5.4
76												4.5

Notes:

1. Area marked with "▲" use 105t turntable counterweight + 40t car-body counterweight; area marked with "★" use 115t turntable counterweight + 40t car-body counterweight; area with no mark use 125t turntable counterweight + 40t car-body counterweight; when the required lifting weight exceeds 260t, please purchase special structure parts.
2. For boom raising, position crawler drive sprocket at the rear of the crane.
3. For boom sections, tower jib rear pendant needs to be removed; for boom tapered section, tower jib guide pulley needs to be removed.

Typical Working Conditions

Boom working condition_ boom single top aux. hook (with boom main hook, HBS/2)

Boom working condition_ boom single top aux. hook working range (with boom main hook, HBS/2)

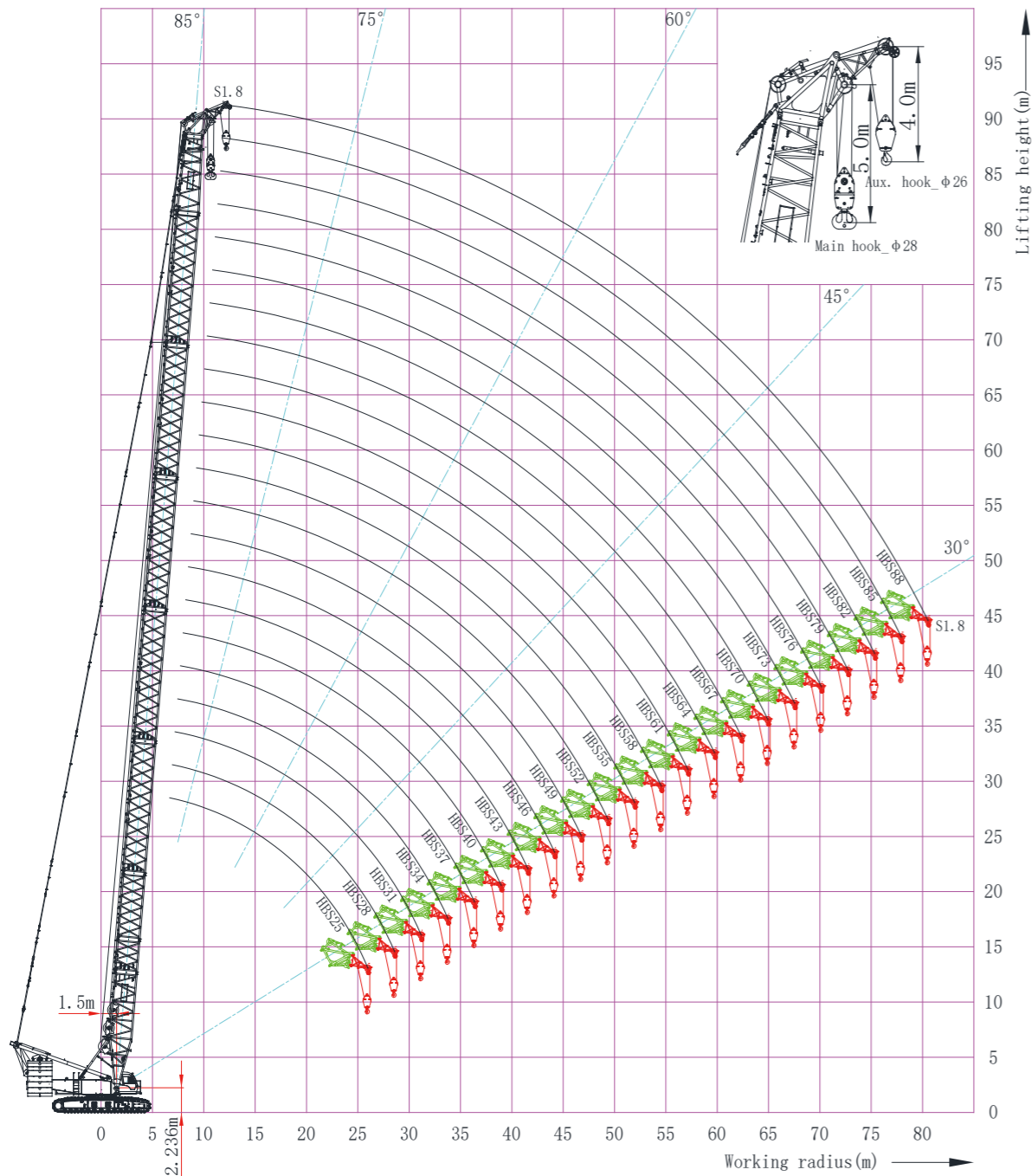

Boom working condition_ boom single top aux. hook working range (with boom main hook, HBS/2)

Boom single top aux. hook lifting capacity table (with boom main hook, HBS/2_125t+40t)

HBS/2 Radius (m)	Boom length (m)											
	25 t	31 t	37 t	43 t	49 t	55 t	61 t	67 t	73 t	79 t	85 t	88 t
7	28.0★											
8	28.0★	28.0★	28.0★									
9	28.0	28.0	28.0	28.0	28.0							
10	28.0	28.0	28.0	28.0	28.0	28.0						
11	28.0	28.0	28.0	28.0	28.0	28.0	28.0	28.0				
12	28.0	28.0	28.0	28.0	28.0	28.0	28.0	28.0	28.0	28.0		
14	28.0	28.0	28.0	28.0	28.0	28.0	28.0	28.0	28.0	28.0	28.0	28.0
16	28.0	28.0	28.0	28.0	28.0	28.0	28.0	28.0	28.0	28.0	28.0	28.0
18	28.0	28.0	28.0	28.0	28.0	28.0	28.0	28.0	28.0	28.0	28.0	28.0
20	28.0	28.0	28.0	28.0	28.0	28.0	28.0	28.0	28.0	28.0	28.0	28.0
22	28.0	28.0	28.0	28.0	28.0	28.0	28.0	28.0	28.0	28.0	28.0	28.0
24		28.0	28.0	28.0	28.0	28.0	28.0	28.0	28.0	28.0	28.0	28.0
26		28.0	28.0	28.0	28.0	28.0	28.0	28.0	28.0	28.0	28.0	28.0
28		28.0	28.0	28.0	28.0	28.0	28.0	28.0	28.0	28.0	28.0	28.0
30			28.0	28.0	28.0	28.0	28.0	28.0	28.0	28.0	28.0	28.0
32			28.0	28.0	28.0	28.0	28.0	28.0	28.0	28.0	28.0	28.0
34			28.0	28.0	28.0	28.0	28.0	28.0	28.0	28.0	28.0	28.0
36				28.0	28.0	28.0	27.7	27.4	26.7	26.2	25.5	25.2
38				26.9	26.4	25.8	25.2	24.8	24.2	23.7	23.0	22.5
40					24.1	23.6	22.9	22.5	21.8	21.3	20.6	20.3
42					22.0	21.5	20.8	20.5	19.8	19.3	18.6	18.2
44					20.2	19.6	19.0	18.6	18.0	17.5	16.8	16.4
46						18.0	17.3	17.0	16.3	15.8	15.1	14.7
48						16.5	15.8	15.5	14.8	14.3	13.6	13.2
50							14.4	14.1	13.4	12.9	12.2	11.9
52							13.2	12.8	12.2	11.7	11.0	10.6
54							12.0	11.7	11.0	10.5	9.8	9.4
56								10.6	9.9	9.4	8.7	8.3
58								9.6	8.9	8.4	7.7	7.3
60								8.6	8.0	7.5	6.8	6.4
64									6.3	5.8	5.0	4.6
68										4.2	3.5	3.1

Notes:

1. Area marked with "★" use 115t turntable counterweight + 40t car-body counterweight; area with no mark use 125t turntable counterweight + 40t car-body counterweight; when the required lifting weight exceeds 260t, please purchase special structure parts.
2. For boom raising, position crawler drive sprocket at the rear of the crane.
3. For boom sections, tower jib rear pendant needs to be removed; for boom tapered section, tower jib guide pulley needs to be removed.

Typical Working Conditions

Boom working condition_boom main hook (with boom single top aux. hook, HBS/1)

Boom working condition_boom main hook working range (with boom single top, HBS/1)

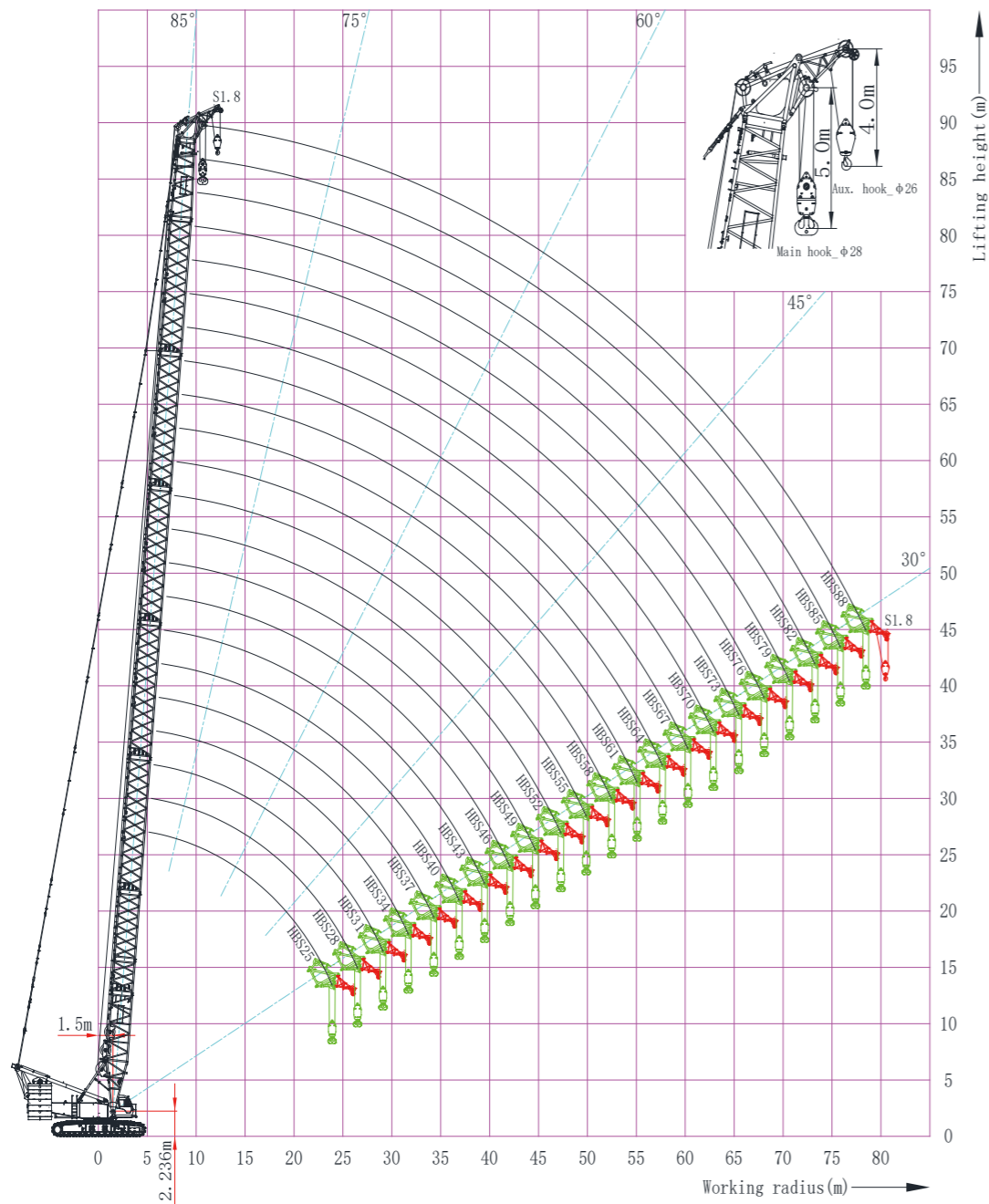

Boom working condition_boom main hook working range (with boom single top, HBS/1)

Boom main hook lifting capacity table (with boom single top aux. hook, HBS/1_125t+40t)

HBS/1 Radius (m)	Boom length (m)											
	25 t	31 t	37 t	43 t	49 t	55 t	61 t	67 t	73 t	79 t	85 t	88 t
6	281.7▲	262.9▲										
7	250.8★	248.3★	235.0★	206.2★								
8	220.8★	218.1★	217.4★	206.2★	191.5	176.5						
9	199.1	198.6	198.0	194.6	190.8	176.5	161.4	153.0				
10	179.2	178.7	175.2	171.8	168.6	165.5	159.7	153.0	136.0	119.0		
11	162.8	159.7	156.5	153.5	150.6	148.0	143.6	138.6	133.6	119.0	101.8	94.4
12	146.8	144.0	141.2	138.5	135.9	133.5	130.4	125.9	121.6	117.4	100.6	93.3
14	121.0	120.0	117.6	115.4	113.2	111.1	109.0	106.0	102.5	99.3	96.0	90.9
16	99.7	99.6	99.3	98.3	96.3	94.5	92.6	90.9	88.0	85.3	82.7	81.3
18	84.2	84.1	83.7	83.3	82.9	81.8	80.4	78.9	76.7	74.3	72.0	70.9
20	72.5	72.3	71.9	71.5	71.0	70.5	70.0	69.0	67.5	65.5	63.5	62.4
22	63.3	63.2	62.8	62.4	61.8	61.3	60.7	60.4	59.6	58.2	56.3	55.3
24		55.7	55.3	54.9	54.3	53.8	53.2	52.9	52.3	51.8	50.3	49.4
26		49.6	49.2	48.8	48.2	47.7	47.1	46.8	46.2	45.7	45.1	44.4
28		44.5	44.1	43.7	43.2	42.6	42.0	41.7	41.0	40.5	39.8	39.5
30			39.7	39.3	38.7	38.2	37.5	37.2	36.6	36.1	35.4	35.1
32			36.0	35.6	35.0	34.4	33.8	33.5	32.8	32.3	31.7	31.3
34			32.7	32.3	31.7	31.2	30.6	30.2	29.6	29.0	28.4	28.0
36				29.5	28.9	28.3	27.7	27.4	26.7	26.2	25.5	25.2
38				26.9	26.4	25.8	25.2	24.8	24.2	23.7	23.0	22.5
40					24.1	23.6	22.9	22.5	21.8	21.3	20.6	20.3
42					22.0	21.5	20.8	20.5	19.8	19.3	18.6	18.2
44					20.2	19.6	19.0	18.6	18.0	17.5	16.8	16.4
46						18.0	17.3	17.0	16.3	15.8	15.1	14.7
48						16.5	15.8	15.5	14.8	14.3	13.6	13.2
50							14.4	14.1	13.4	12.9	12.2	11.9
52							13.2	12.8	12.2	11.7	11.0	10.6
54							12.0	11.7	11.0	10.5	9.8	9.4
56								10.6	9.9	9.4	8.7	8.3
58								9.6	8.9	8.4	7.7	7.3
60								8.6	8.0	7.5	6.8	6.4
64									6.3	5.8	5.0	4.6
68										4.2	3.5	3.1

Notes:

1. Area marked with "▲" use 105t turntable counterweight + 40t car-body counterweight; area marked with "★" use 115t turntable counterweight + 40t car-body counterweight; area with no mark use 125t turntable counterweight + 40t car-body counterweight; when the required lifting weight exceeds 260t, please purchase special structure parts.
2. For boom raising, position crawler drive sprocket at the rear of the crane.
3. For boom sections, tower jib rear pendant needs to be removed; for boom tapered section, tower jib guide pulley needs to be removed.

Light boom working condition

A. Light boom combination without tower jib single top

Name & Number	Boom base 10.5m	Boom insert 3m	Boom insert 6m	Boom insert 12mA	Boom tapered section 7m	Tower jib insert 6mA	Tower jib insert 6mB	Tower jib insert 12m	Tower jib top 9m
LB65.5	1	1	1	1	1	1	0	1	1
LB68.5	1	0	0	2	1	1	0	1	1
LB71.5	1	1	0	2	1	1	0	1	1
*LB74.5	1	0	1	2	1	1	0	1	1
*LB77.5	1	1	1	2	1	1	0	1	1
*LB80.5	1	0	0	3	1	1	0	1	1
**LB83.5	1	1	1	2	1	1	1	1	1
**LB86.5	1	0	0	3	1	1	1	1	1
**LB89.5	1	1	0	3	1	1	1	1	1
**LB92.5	1	0	1	3	1	1	1	1	1
**LB95.5	1	1	1	3	1	1	1	1	1
**LB98.5	1	0	0	3	1	1	1	2	1
**LB101.5	1	1	0	3	1	1	1	2	1
**LB104.5	1	0	1	3	1	1	1	2	1
**LB107.5	1	1	1	3	1	1	1	2	1

B. Light boom combination with tower jib single top

Name & Number	Boom base 10.5m	Boom inser 3m	Boom inser 6m	Boom inser 12mA	Boom tapered section 7m	Tower jib insert 6mA	Tower jib insert 6mB	Tower jib insert 12m	Tower jib top 9m	Tower jib single top
LB65.5	1	1	1	1	1	1	0	1	1	1
LB68.5	1	0	0	2	1	1	0	1	1	1
LB71.5	1	1	0	2	1	1	0	1	1	1
*LB74.5	1	0	1	2	1	1	0	1	1	1
*LB77.5	1	1	1	2	1	1	0	1	1	1
*LB80.5	1	0	0	3	1	1	0	1	1	1
**LB83.5	1	1	1	2	1	1	1	1	1	1
**LB86.5	1	0	0	3	1	1	1	1	1	1
**LB89.5	1	1	0	3	1	1	1	1	1	1
**LB92.5	1	0	1	3	1	1	1	1	1	1
**LB95.5	1	1	1	3	1	1	1	1	1	1
**LB98.5	1	0	0	3	1	1	1	2	1	1
**LB101.5	1	1	0	3	1	1	1	2	1	1
**LB104.5	1	0	1	3	1	1	1	2	1	1

Notes:

- "**" -- Light boom length needs to use 1.25m center hitch, "***" -- Light boom length needs to use 1.25m and 2.62m center hitch.
- For boom sections, boom outer pendant used for tower jib and fixed jib need to be removed, for boom tapered section, tower jib guide pulley needs to be installed.

C. Boom raising table in light boom working condition

Boom raising table in light boom working condition without tower jib single top (LB /1)

LB/1	Counterweight combination: turntable counterweight (t)+car-body counterweight (t)			
	125+40	115+40	105+40	95+40
Light boom combination				
LB65.5	○	○	○	○
LB68.5	○	○	○	○
LB71.5	○	○	○	○
LB74.5	○	○	○	○
LB77.5	○	○	○	○
LB80.5	○	○	○	○
LB83.5	○	○	○	○
LB86.5	○	○	○	●
LB89.5	○	○	●	●
LB92.5	○	●	●	●
LB95.5	●	●	●	●
LB98.5	●	●	●	●
LB101.5	●	●	●	×
LB104.5	●	●	×	×
LB107.5	●	×	×	×

Boom raising table in light boom working condition with tower jib single top (LBS/1 & LBS/2)

LBS/1 & LBS/2	Counterweight combination: turntable counterweight (t)+car-body counterweight (t)			
	125+40	115+40	105+40	95+40
Light boom combination				
LBS65.5	○	○	○	○
LBS68.5	○	○	○	○
LBS71.5	○	○	○	○
LBS74.5	○	○	○	○
LBS77.5	○	○	○	○
LBS80.5	○	○	○	○
LBS83.5	○	○	○	●
LBS86.5	○	○	●	●
LBS89.5	○	●	●	●
LBS92.5	●	●	●	●
LBS95.5	●	●	●	●
LBS98.5	●	●	●	×
LBS101.5	●	●	×	×
LBS104.5	●	×	×	×

LBS104.5 ● × × ×

Notes:

- "○" -- can raise boom; "●" -- wedge required to raise boom; "×" -- cannot raise boom, this working condition cannot be used.
- For boom sections, tower jib rear pendant needs to be removed; for boom tapered section, tower jib guide pulley needs to be installed.
- For boom raising, position crawler drive sprocket at the rear of the crane.

Light boom working condition

Light boom working condition_light boom main hook (without tower jib single top, LB/1)

Light boom working condition_light boom main hook working range (without tower jib single top, LB/1)

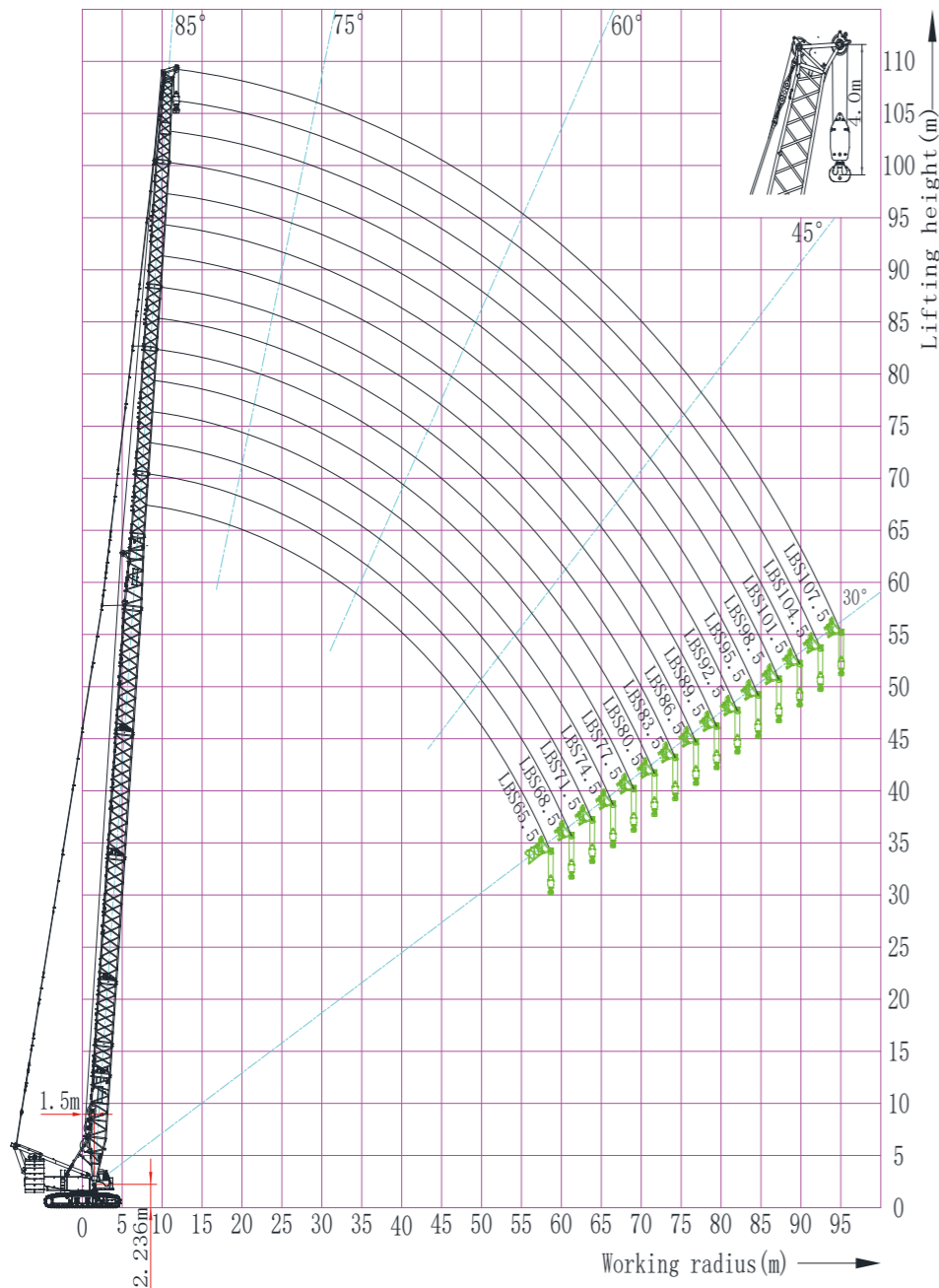

Light boom working condition_boom main hook working range (without light boom single top, LB/1)

Light boom working condition_light boom main hook lifting capacity table (without tower jib single top, LB/1_125t+40t)

LB/1 Radius (m)	Light boom length (m)														
	65.5	68.5	71.5	74.5	77.5	80.5	83.5	86.5	89.5	92.5	95.5	98.5	101.5	104.5	107.5
	t	t	t	t	t	t	t	t	t	t	t	t	t	t	t
10	118.0	113.0	108.7												
11	116.6	112.2	107.8	98.6	97.4	95.7									
12	116.8	111.5	107.2	96.5	95.6	94.2	77.5	77.0	76.2						
14	104.9	103.0	100.8	92.5	92.0	91.1	74.1	73.9	73.4	72.7	71.5	55.5	54.9	53.9	51.7
16	91.6	90.0	88.4	86.8	85.2	83.8	70.9	71.1	70.9	70.3	69.4	53.4	53.5	52.6	50.5
18	81.1	79.7	78.4	76.9	75.6	74.3	68.0	68.4	68.3	68.1	67.4	51.6	51.3	50.8	49.3
20	72.5	71.4	70.2	68.9	67.7	66.6	64.7	64.6	63.5	62.5	61.4	49.7	49.6	49.2	48.0
22	64.4	64.1	63.4	62.2	61.1	60.1	59.4	58.4	57.4	56.4	55.4	48.1	47.9	47.8	46.8
24	57.2	57.0	56.6	56.2	55.6	54.7	54.0	53.1	52.2	51.3	50.4	46.2	46.4	46.4	45.6
26	51.3	51.0	50.7	50.3	50.0	49.7	49.3	48.5	47.7	46.8	46.0	45.0	44.9	44.4	43.6
28	46.4	46.1	45.8	45.3	45.0	44.7	44.6	44.3	43.7	43.0	42.2	42.2	41.5	40.7	39.9
30	42.2	41.9	41.6	41.1	40.8	40.5	40.4	40.1	39.8	39.4	38.8	38.9	38.2	37.5	36.7
32	38.6	38.3	37.9	37.5	37.2	36.9	36.8	36.5	36.1	35.8	35.4	35.9	35.3	34.6	33.9
34	35.4	35.2	34.8	34.4	34.0	33.7	33.6	33.3	33.0	32.6	32.3	32.7	32.4	32.0	31.3
36	32.7	32.4	32.0	31.6	31.3	31.0	30.9	30.5	30.2	29.9	29.5	29.9	29.6	29.3	28.9
38	30.2	30.0	29.6	29.2	28.8	28.5	28.4	28.1	27.7	27.4	27.0	27.5	27.1	26.8	26.4
40	28.1	27.8	27.4	27.0	26.7	26.4	26.2	25.9	25.6	25.2	24.9	25.3	24.9	24.6	24.3
42	26.1	25.9	25.5	25.1	24.7	24.4	24.3	24.0	23.6	23.3	22.9	23.3	23.0	22.6	22.3
44	24.4	24.1	23.7	23.3	22.9	22.7	22.5	22.2	21.9	21.5	21.1	21.6	21.2	20.9	20.5
46	22.8	22.5	22.1	21.7	21.4	21.1	20.9	20.6	20.3	19.9	19.5	20.0	19.6	19.3	18.9
48	21.3	21.1	20.7	20.3	19.9	19.6	19.5	19.2	18.8	18.5	18.1	18.5	18.2	18.2	17.8
50	20.0	19.7	19.4	19.0	18.6	18.3	18.2	17.8	17.5	17.1	16.7	17.2	17.3	16.9	16.3
52	18.8	18.5	18.1	17.7	17.4	17.1	16.9	16.6	16.3	15.9	15.6	16.4	16.1	15.7	15.1
54	17.7	17.4	17.0	16.6	16.2	15.9	15.8	15.5	15.1	14.9	14.6	15.2	14.9	14.3	14.0
56	16.6	16.3	16.0	15.6	15.2	14.9	14.8	14.5	14.1	13.9	13.5	14.0	13.8	13.4	12.9
58	15.6	15.4	15.0	14.6	14.2	13.9	13.8	13.5	13.1	12.9	12.5	13.0	12.9	12.4	11.9
60		14.5	14.1	13.7	13.3	13.0	12.9	12.6	12.3	12.0	11.7	12.2	11.9	11.5	11.0
64				12.1	11.7	11.4	11.3	11.0	10.7	10.4	10.1	10.5	10.3	10.0	9.3
68					10.3	10.0	9.9	9.6	9.3	9.1	8.8	9.2	8.9	8.6	7.9
72							8.6	8.5	8.2	7.8	7.5	8.0	7.7	7.4	6.6
76								7.3	7.0	6.8	6.5	6.9	6.6	6.3	5.5
80										5.8	5.5	5.9	5.6	5.3	4.5
84											4.6	5.0	4.7	4.5	3.6
88													3.9	3.7	

Notes:

1. For boom raising, position crawler drive sprocket at the rear of the crane.
2. For boom sections, boom outer pendant used for tower jib and fixed jib need to be removed, for boom tapered section, tower jib guide pulley needs to be installed.

Light boom working condition

Light boom working condition_light boom single top aux. hook (with light boom main hook, LBS/2)

Light boom working condition_light boom single top aux. hook working range (with light boom main hook, LBS/2)

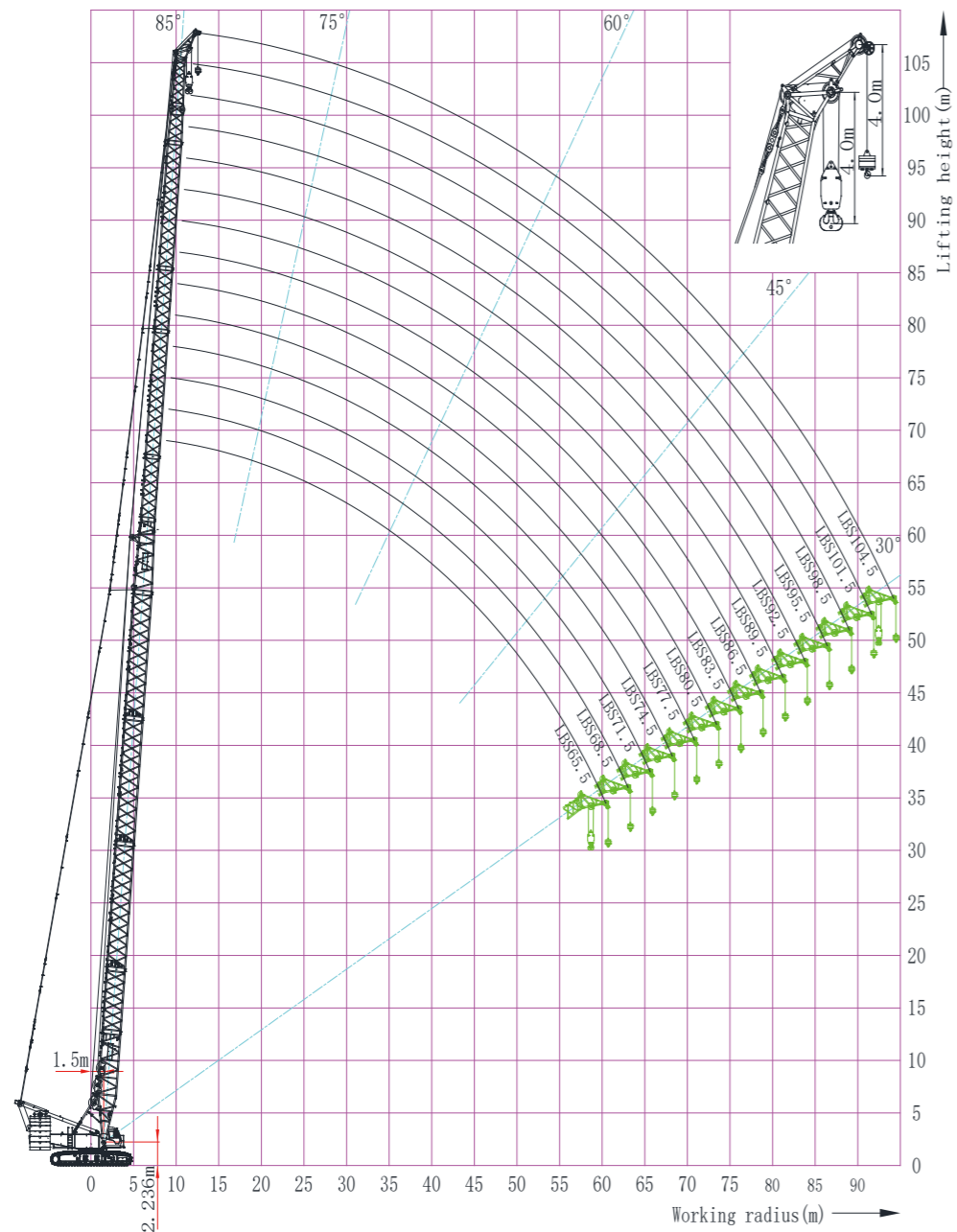

Light boom working condition_light boom single top aux. hook working range (with light boom main hook, LBS/2)

Light boom working condition _ Light boom single top aux. hook lifting capacity table (with light boom main hook, LBS/2_125t+40t)

LBS/2 Radius (m)	Light boom length (m)													
	65.5	68.5	71.5	74.5	77.5	80.5	83.5	86.5	89.5	92.5	95.5	98.5	101.5	104.5
11	14.0	14.0	14.0											
12	14.0	14.0	14.0	14.0	14.0	14.0								
14	14.0	14.0	14.0	14.0	14.0	14.0	14.0	14.0	14.0					
16	14.0	14.0	14.0	14.0	14.0	14.0	14.0	14.0	14.0	14.0	14.0	14.0	14.0	14.0
18	14.0	14.0	14.0	14.0	14.0	14.0	14.0	14.0	14.0	14.0	14.0	14.0	14.0	14.0
20	14.0	14.0	14.0	14.0	14.0	14.0	14.0	14.0	14.0	14.0	14.0	14.0	14.0	14.0
22	14.0	14.0	14.0	14.0	14.0	14.0	14.0	14.0	14.0	14.0	14.0	14.0	14.0	14.0
24	14.0	14.0	14.0	14.0	14.0	14.0	14.0	14.0	14.0	14.0	14.0	14.0	14.0	14.0
26	14.0	14.0	14.0	14.0	14.0	14.0	14.0	14.0	14.0	14.0	14.0	14.0	14.0	14.0
28	14.0	14.0	14.0	14.0	14.0	14.0	14.0	14.0	14.0	14.0	14.0	14.0	14.0	14.0
30	14.0	14.0	14.0	14.0	14.0	14.0	14.0	14.0	14.0	14.0	14.0	14.0	14.0	14.0
32	14.0	14.0	14.0	14.0	14.0	14.0	14.0	14.0	14.0	14.0	14.0	14.0	14.0	14.0
34	14.0	14.0	14.0	14.0	14.0	14.0	14.0	14.0	14.0	14.0	14.0	14.0	14.0	14.0
36	14.0	14.0	14.0	14.0	14.0	14.0	14.0	14.0	14.0	14.0	14.0	14.0	14.0	14.0
38	14.0	14.0	14.0	14.0	14.0	14.0	14.0	14.0	14.0	14.0	14.0	14.0	14.0	14.0
40	14.0	14.0	14.0	14.0	14.0	14.0	14.0	14.0	14.0	14.0	14.0	14.0	14.0	14.0
42	14.0	14.0	14.0	14.0	14.0	14.0	14.0	14.0	14.0	14.0	14.0	14.0	14.0	14.0
44	14.0	14.0	14.0	14.0	14.0	14.0	14.0	14.0	14.0	14.0	14.0	14.0	14.0	14.0
46	14.0	14.0	14.0	14.0	14.0	14.0	14.0	14.0	14.0	14.0	14.0	14.0	14.0	14.0
48	14.0	14.0	14.0	14.0	14.0	14.0	14.0	14.0	14.0	14.0	14.0	14.0	14.0	14.0
50	14.0	14.0	14.0	14.0	14.0	14.0	14.0	14.0	14.0	13.6	13.2	13.7	13.8	13.4
52	14.0	14.0	14.0	14.0	13.9	13.6	13.4	13.1	12.8	12.4	12.1	12.9	12.6	12.2
54	14.0	13.9	13.5	13.1	12.7	12.4	12.3	12.0	11.6	11.4	11.1	11.7	11.4	10.8
56	13.1	12.8	12.5	12.1	11.7	11.4	11.3	11.0	10.6	10.4	10.0	10.5	10.3	9.8
58	12.1	11.9	11.5	11.1	10.7	10.4	10.3	10.0	9.6	9.4	9.0	9.5	9.4	8.8
60		11.0	10.6	10.2	9.8	9.5	9.4	9.1	8.8	8.5	8.2	8.7	8.4	7.9
64				8.6	8.2	7.9	7.8	7.5	7.2	6.9	6.6	7.0	6.8	6.3
68					6.8	6.5	6.4	6.1	5.8	5.6	5.3	5.6	5.3	4.9
72							5.1	5.0	4.7	4.3	4.0	4.4	4.0	3.6
76								3.8	3.5	3.3	3.0	3.2		

Notes:

1. For boom raising, position crawler drive sprocket at the rear of the crane.
2. For boom sections, boom outer pendant used for tower jib and fixed jib need to be removed, for boom tapered section, tower jib guide pulley needs to be installed.

Light boom working condition

Light boom working condition _ light boom main hook (with tower jib single top aux. hook, LBS/1)

Light boom working condition _ light boom main hook working range (with tower jib single top aux. hook, LBS/1)

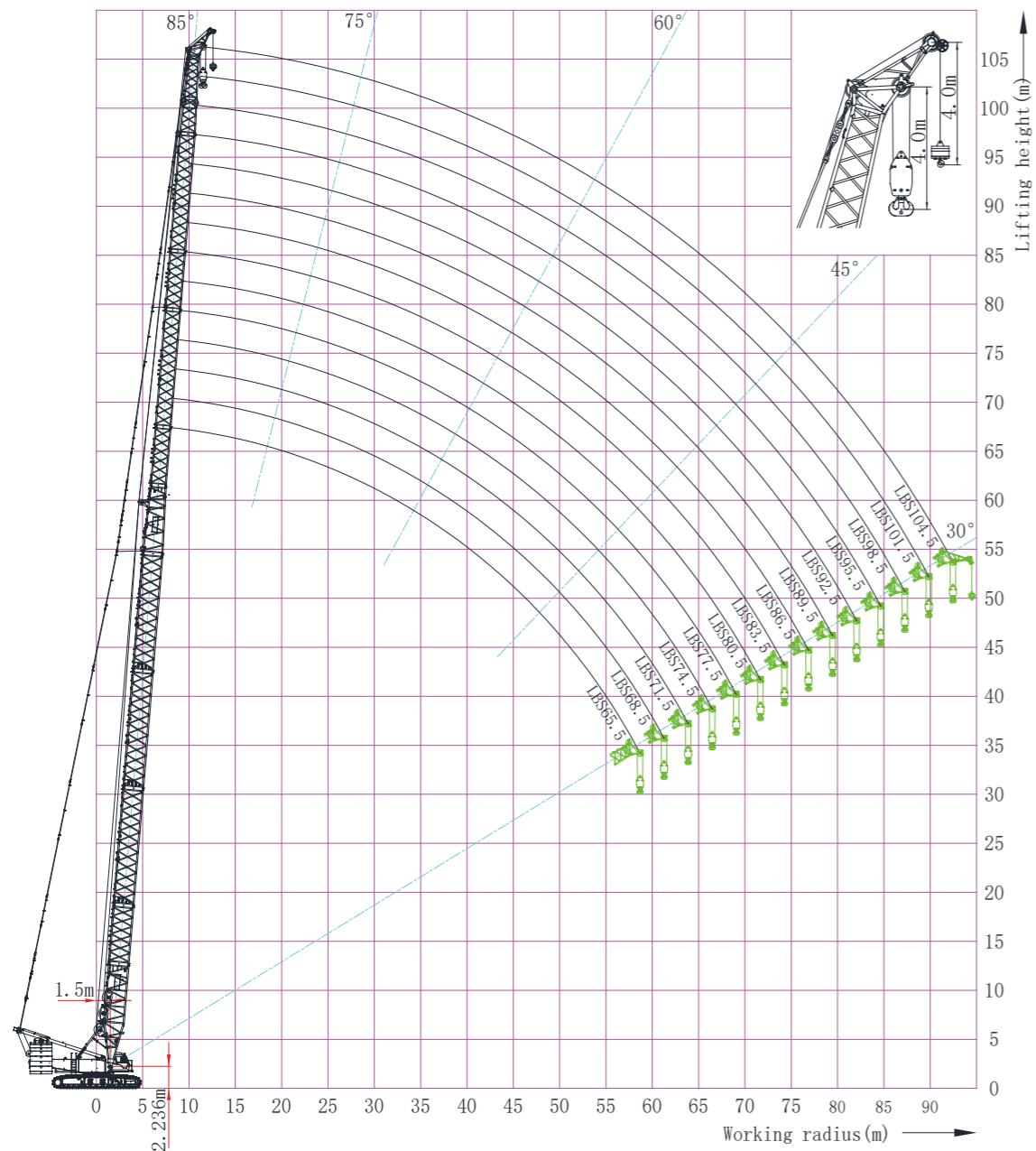

Light boom working condition_light boom main hook working range (with light boom single top,LBS/1)

Light boom working condition _ light boom main hook lifting capacity table (with light boom single top aux. hook, LBS/1_125t+40t)

LBS/1 Radius (m)	Light boom length (m)													
	65.5 t	68.5 t	71.5 t	74.5 t	77.5 t	80.5 t	83.5 t	86.5 t	89.5 t	92.5 t	95.5 t	98.5 t	101.5 t	104.5 t
10	114.0	109.5	105.2											
11	113.1	108.7	104.3	95.1	93.9	92.2								
12	113.3	108.0	103.7	93.0	92.1	90.7	74.0	73.5	72.7					
14	101.4	99.5	97.3	89.0	88.5	87.6	70.6	70.4	69.9	69.2	68.0	52.0	51.4	50.4
16	88.1	86.5	84.9	83.3	81.7	80.3	67.4	67.6	67.4	66.8	65.9	49.9	50.0	49.1
18	77.6	76.2	74.9	73.4	72.1	70.8	64.5	64.9	64.8	64.6	63.9	48.1	47.8	47.3
20	69.0	67.9	66.7	65.4	64.2	63.1	61.2	61.1	60.0	59.0	57.9	46.2	46.1	45.7
22	60.9	60.6	59.9	58.7	57.6	56.6	55.9	54.9	53.9	52.9	51.9	44.6	44.4	44.3
24	53.7	53.5	53.1	52.7	52.1	51.2	50.5	49.6	48.7	47.8	46.9	42.7	42.9	42.9
26	47.8	47.5	47.2	46.8	46.5	46.2	45.8	45.0	44.2	43.3	42.5	41.5	41.4	40.9
28	42.9	42.6	42.3	41.8	41.5	41.2	41.1	40.8	40.2	39.5	38.7	38.7	38.0	37.2
30	38.7	38.4	38.1	37.6	37.3	37.0	36.9	36.6	36.3	35.9	35.3	35.4	34.7	34.0
32	35.1	34.8	34.4	34.0	33.7	33.4	33.3	33.0	32.6	32.3	31.9	32.4	31.8	31.1
34	31.9	31.7	31.3	30.9	30.5	30.2	30.1	29.8	29.5	29.1	28.8	29.2	28.9	28.5
36	29.2	28.9	28.5	28.1	27.8	27.5	27.4	27.0	26.7	26.4	26.0	26.4	26.1	25.8
38	26.7	26.5	26.1	25.7	25.3	25.0	24.9	24.6	24.2	23.9	23.5	24.0	23.6	23.3
40	24.6	24.3	23.9	23.5	23.2	22.9	22.7	22.4	22.1	21.7	21.4	21.8	21.4	21.1
42	22.6	22.4	22.0	21.6	21.2	20.9	20.8	20.5	20.1	19.8	19.4	19.8	19.5	19.1
44	20.9	20.6	20.2	19.8	19.4	19.2	19.0	18.7	18.4	18.0	17.6	18.1	17.7	17.4
46	19.3	19.0	18.6	18.2	17.9	17.6	17.4	17.1	16.8	16.4	16.0	16.5	16.1	15.8
48	17.8	17.6	17.2	16.8	16.4	16.1	16.0	15.7	15.3	15.0	14.6	15.0	14.7	14.7
50	16.5	16.2	15.9	15.5	15.1	14.8	14.7	14.3	14.0	13.6	13.2	13.7	13.8	13.4
52	15.3	15.0	14.6	14.2	13.9	13.6	13.4	13.1	12.8	12.4	12.1	12.9	12.6	12.2
54	14.2	13.9	13.5	13.1	12.7	12.4	12.3	12.0	11.6	11.4	11.1	11.7	11.4	10.8
56	13.1	12.8	12.5	12.1	11.7	11.4	11.3	11.0	10.6	10.4	10.0	10.5	10.3	9.8
58	12.1	11.9	11.5	11.1	10.7	10.4	10.3	10.0	9.6	9.4	9.0	9.5	9.4	8.8
60		11.0	10.6	10.2	9.8	9.5	9.4	9.1	8.8	8.5	8.2	8.7	8.4	7.9
64				8.6	8.2	7.9	7.8	7.5	7.2	6.9	6.6	7.0	6.8	6.3
68					6.8	6.5	6.4	6.1	5.8	5.6	5.3	5.6	5.3	4.9
72								5.1	5.0	4.7	4.3	4.0	4.0	3.6
76									3.8	3.5	3.3	3.0	3.2	

Notes:

1. For boom raising, position crawler drive sprocket at the rear of the crane.
2. For boom sections, boom outer pendant used for tower jib and fixed jib need to be removed, for boom tapered section, tower jib guide pulley needs to be installed.

Tower jib working condition

A. Boom combinations in tower jib working condition

Name & Number Boom combination	Boom base 10.5m	Boom insert 3m	Boom insert 6m	Boom insert 12mA	Boom tapered section 7m	Boom connection section 1.5m
H25	1	0	1	0	1	1
H28	1	1	1	0	1	1
H31	1	0	0	1	1	1
H34	1	1	0	1	1	1
H37	1	0	1	1	1	1
H40	1	1	1	1	1	1
H43	1	0	1	2	1	1
H46	1	1	0	2	1	1
H49	1	0	1	2	1	1
H52	1	1	1	2	1	1
H55	1	0	0	3	1	1
H58	1	1	0	3	1	1
H61	1	0	1	3	1	1
H64	1	1	1	3	1	1

Notes:

1. For boom sections, boom outer pendant used for fixed jib needs to be removed; for boom tapered section, tower jib guide pulley needs to be installed.

B. Jib combinations in tower jib working condition

Name & Number Jib combinations	Tower jib base 9m	Tower jib insert 6mA	Tower jib insert 6mB	Tower jib insert 12m	Tower jib top 9m	Tower jib single top
W(S)24	1	1	0	0	1	(1)
W(S)30	1	1	1	0	1	(1)
W(S)36	1	1	0	1	1	(1)
W(S)42	1	1	1	1	1	(1)
W(S)48	1	1	0	2	1	(1)
W(S)54	1	1	1	2	1	(1)
◇ W(S)60	1	1	2	2	1	(1)

Notes:

1. () — If it needs to use tower jib single top; ◇—tower jib length needs to use 2.59m center hitch;

Boom raising table in tower jib working condition

Boom raising table in tower jib working condition (without boom pulley block and tower jib single top, HW/1

Turntable counterweight 125t+ car-body counterweight 40t	Tower jib combination							
	Boom combination	W24	W30	W36	W42	W48	W54	*W60
H25	○	○	○	○	○	○	○	○
H28	○	○	○	○	○	○	○	○
H31	○	○	○	○	○	○	○	○
H34	○	○	○	○	○	○	○	○
H37	○	○	○	○	○	○	○	○
H40	○	○	○	○	○	○	○	○
H43	○	○	○	○	○	○	○	●
H46	○	○	○	○	○	○	●	●
H49	○	○	○	○	●	●	●	●
H52	○	○	○	●	●	●	●	●
H55	○	○	●	●	●	●	●	●
H58	○	●	●	●	●	●	●	●
H61	●	●	●	●	●	●	●	●
H64	●	●	●	●	●	●	●	●

Turntable counterweight 115t+ car-body counterweight 40t	Tower jib combination							
	Boom combination	W24	W30	W36	W42	W48	W54	*W60
H25	○	○	○	○	○	○	○	○
H28	○	○	○	○	○	○	○	○
H31	○	○	○	○	○	○	○	○
H34	○	○	○	○	○	○	○	○
H37	○	○	○	○	○	○	○	○
H40	○	○	○	○	○	○	○	●
H43	○	○	○	○	○	○	●	●
H46	○	○	○	○	○	○	●	●
H49	○	○	○	○	●	●	●	●
H52	○	○	○	○	●	●	●	●
H55	○	○	○	○	●	●	●	●
H58	○	○	○	○	●	●	●	●
H61	○	○	○	○	●	●	●	●

Tower jib working condition

Turntable counterweight 105t+ car-body counterweight 40t	Tower jib combination						
Boom combination	W24	W30	W36	W42	W48	W54	*W60
H25	○	○	○	○	○	○	○
H28	○	○	○	○	○	○	○
H31	○	○	○	○	○	○	○
H34	○	○	○	○	○	○	○
H37	○	○	○	○	○	○	●
H40	○	○	○	○	○	●	●
H43	○	○	○	○	●	●	●
H46	○	○	○	●	●	●	●
H49	○	○	●	●	●	●	●
H52	○	●	●	●	●	●	●
H55	●	●	●	●	●	●	●
H58	●	●	●	●	●	●	●

Turntable counterweight 95t+ car-body counterweight 40t	Tower jib combination						
Boom combination	W24	W30	W36	W42	W48	W54	*W60
H25	○	○	○	○	○	○	○
H28	○	○	○	○	○	○	○
H31	○	○	○	○	○	○	○
H34	○	○	○	○	○	○	○
H37	○	○	○	○	○	○	●
H40	○	○	○	○	○	●	●
H43	○	○	○	○	●	●	●
H46	○	○	●	●	●	●	●
H49	○	●	●	●	●	●	●
H52	●	●	●	●	●	●	●
H55	●	●	●	●	●	●	●

Boom raising table in tower jib working condition (without boom pulley block, with tower jib single top, HWS/1&HWS/3)

Turntable counterweight 125t+ car-body counterweight 40t	Tower jib combination						
Boom combination	W24	W30	W36	W42	W48	W54	*W60
H25	○	○	○	○	○	○	○
H28	○	○	○	○	○	○	○
H31	○	○	○	○	○	○	○
H34	○	○	○	○	○	○	○
H37	○	○	○	○	○	○	○
H40	○	○	○	○	○	○	●
H43	○	○	○	○	○	●	●
H46	○	○	○	○	●	●	●
H49	○	○	○	●	●	●	●
H52	○	○	●	●	●	●	●
H55	○	●	●	●	●	●	●
H58	●	●	●	●	●	●	●
H61	●	●	●	●	●	●	●

Turntable counterweight 115t+ car-body counterweight 40t	Tower jib combination						
Boom combination	W24	W30	W36	W42	W48	W54	*W60
H25	○	○	○	○	○	○	○
H28	○	○	○	○	○	○	○
H31	○	○	○	○	○	○	○
H34	○	○	○	○	○	○	○
H37	○	○	○	○	○	○	●
H40	○	○	○	○	○	●	●
H43	○	○	○	○	●	●	●
H46	○	○	○	●	●	●	●
H49	○	○	●	●	●	●	●
H52	○	●	●	●	●	●	●
H55	●	●	●	●	●	●	●
H58	●	●	●	●	●	●	●

Tower jib working condition

Turntable counterweight 105t+ car-body counterweight 40t	Tower jib combination						
	W24	W30	W36	W42	W48	W54	*W60
Boom combination							
H25	○	○	○	○	○	○	○
H28	○	○	○	○	○	○	○
H31	○	○	○	○	○	○	○
H34	○	○	○	○	○	○	○
H37	○	○	○	○	○	○	●
H40	○	○	○	○	○	●	●
H43	○	○	○	○	●	●	●
H46	○	○	●	●	●	●	●
H49	○	●	●	●	●	●	●
H52	●	●	●	●	●	●	●
H55	●	●	●	●	●	●	●

Turntable counterweight 95t+ car-body counterweight 40t	Tower jib combination						
	W24	W30	W36	W42	W48	W54	*W60
Boom combination							
H25	○	○	○	○	○	○	○
H28	○	○	○	○	○	○	○
H31	○	○	○	○	○	○	○
H34	○	○	○	○	○	○	●
H37	○	○	○	○	○	●	●
H40	○	○	○	○	●	●	●
H43	○	○	●	●	●	●	●
H46	○	●	●	●	●	●	●
H49	●	●	●	●	●	●	●
H52	●	●	●	●	●	●	●

Notes:

1. "○" -- can raise boom; "●" -- wedge required to raise boom
2. For boom raising, position crawler drive sprocket at the rear of the crane.

Tower jib working condition_ tower jib main hook (without boom pulley block and tower jib single top, HW/1)

Boom raising table in tower jib working condition (without boom pulley block and tower jib single top, HW/1)

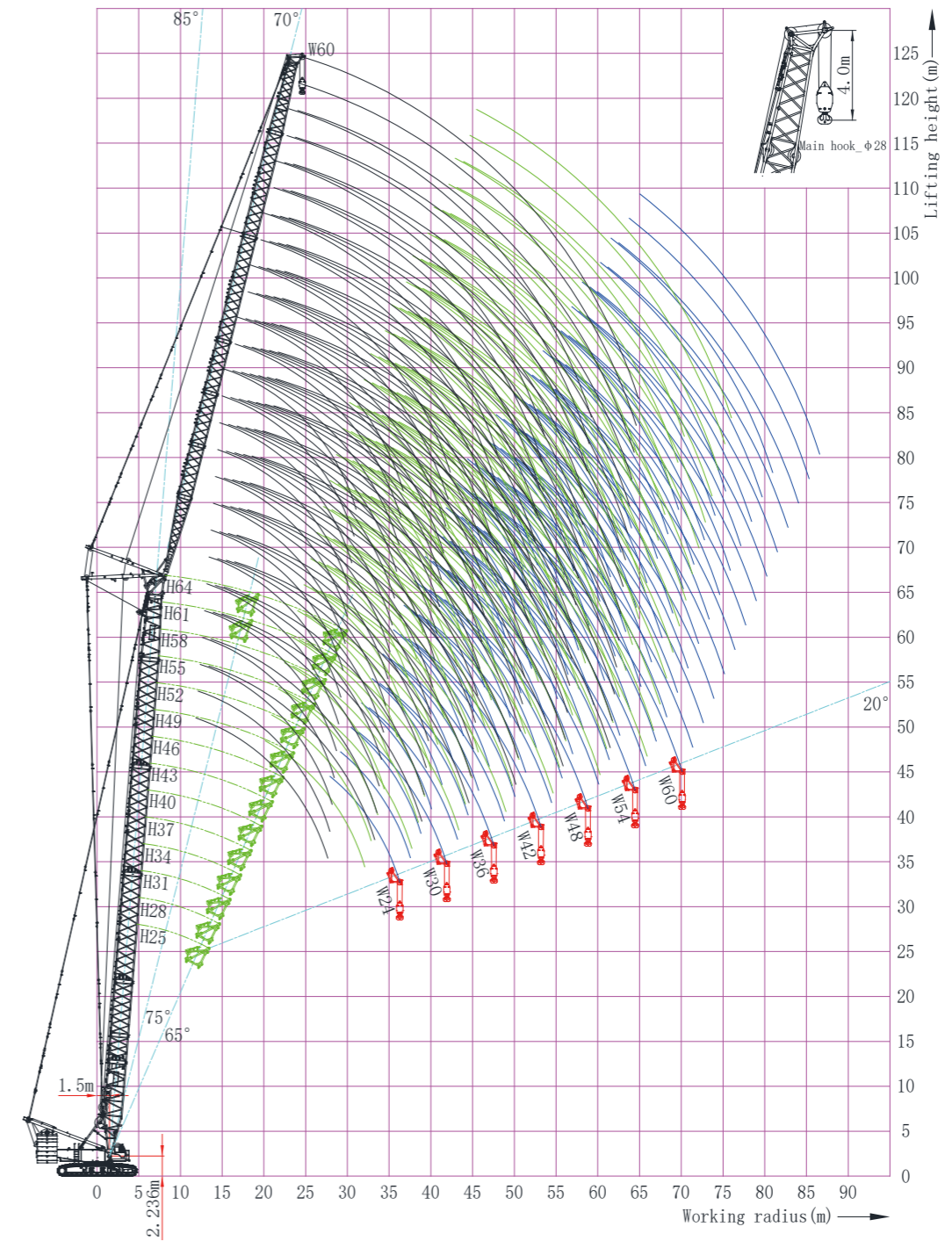

Tower jib working condition_ tower jib main hook working range (without boom pulley block and tower jib single top, HW/1)

Tower jib working condition

Tower jib working condition _ tower jib main hook lifting capacity table (without boom pulley block and tower jib single top, HW/1_85°_125t+40t_25m)

Boom length (m) HW/1	25						
	Tower jib length (m)						
	24	30	36	42	48	54	60
Radius (m)	t	t	t	t	t	t	t
12	130.0						
13	127.0						
14	117.3	102.6					
15	108.9	101.3	86.0				
16	101.4	100.0	85.2				
17	95.0	93.6	84.3	72.5			
18	91.6	88.2	83.5	73.5			
19	84.3	85.3	81.7	72.0	69.6		
20	79.8	78.4	77.4	71.5	62.5	51.5	
22	71.5	71.5	71.3	70.4	59.3	51.0	45.1
24	62.8	64.0	64.7	64.7	58.5	50.3	44.7
26	56.3	57.8	57.4	57.8	55.5	49.7	44.2
28		51.5	52.9	53.4	53.9	49.1	43.8
30		46.8	50.0	49.0	48.0	45.8	43.4
32		42.8	44.6	44.9	43.2	43.1	41.6
34			40.0	42.2	41.2	41.2	38.4
36			36.9	37.7	37.1	36.5	35.5
38			32.9	34.4	35.9	34.3	33.0
40				31.5	33.3	31.8	30.9
42				28.2	29.3	30.6	28.9
44				25.2	26.9	29.6	27.0
46					24.4	25.5	25.5
48					22.4	23.4	23.8
50					20.2	21.5	22.7
52						19.6	20.5
54						18.1	18.8
56							17.3
58							16.1
60							14.6
64							

Notes:

1. For boom sections, fixed jib rear pendant needs to be removed; for boom tapered section, tower jib guide pulley needs to be installed.
2. For boom raising, position crawler drive sprocket at the rear of the crane, it is recommended to use auxiliary crane or wedge block to assist boom raising.

Tower jib working condition _ tower jib main hook lifting capacity table (without boom pulley block and tower jib single top, HW/1_85°_125t+40t_28m)

Boom length (m) HW/1	28						
	Tower jib length (m)						
	24	30	36	42	48	54	60
Radius (m)	t	t	t	t	t	t	t
13	125.0						
14	118.0	101.5					
15	110.0	100.4					
16	101.0	99.3	84.2				
17	94.6	93.2	83.4	72.5			
18	91.6	88.2	82.6	73.5			
19	84.3	85.3	81.4	72.0	69.6		
20	79.8	78.4	77.4	71.5	61.7	51.0	
22	71.5	71.5	71.3	70.4	59.3	50.3	44.4
24	62.8	64.0	64.7	64.7	58.0	49.7	44.0
26	56.3	57.8	57.4	57.8	55.5	49.2	43.7
28	49.9	51.5	52.9	53.4	53.9	48.6	43.3
30		46.8	50.0	49.0	48.0	45.8	43.0
32		42.8	44.6	44.9	43.2	43.1	41.5
34			40.0	42.2	41.2	41.2	38.3
36			36.9	37.7	37.1	36.5	35.5
38			32.9	34.4	35.9	34.3	33.0
40				31.5	33.3	31.8	30.9
42				28.2	29.3	30.6	28.9
44				25.2	26.9	29.6	27.0
46					24.4	25.5	25.5
48					22.4	23.4	23.8
50					20.2	21.5	22.7
52						19.6	20.5
54						18.1	18.8
56						16.3	17.3
58							16.1
60							14.6
64							

Notes:

1. For boom sections, fixed jib rear pendant needs to be removed; for boom tapered section, tower jib guide pulley needs to be installed.
2. For boom raising, position crawler drive sprocket at the rear of the crane, it is recommended to use auxiliary crane or wedge block to assist boom raising.

Tower jib working condition

Tower jib working condition _ tower jib main hook lifting capacity table (without boom pulley block and tower jib single top, HW/1_85°_125t+40t_34m)

Boom length (m) HW/1	34						
	Tower jib length (m)						
	24	30	36	42	48	54	60
Radius (m)	t	t	t	t	t	t	t
13	122.0						
14	115.6						
15	107.8	98.0					
16	100.9	97.0	83.3				
17	94.6	92.1	81.1				
18	91.6	88.2	80.6	73.5			
19	84.3	85.3	80.1	70.6	58.8		
20	79.8	78.4	77.4	70.6	58.8		
22	71.5	71.5	71.3	70.4	57.3	49.0	44.1
24	62.7	64.0	64.7	64.7	56.7	48.4	43.1
26	56.3	57.8	57.4	57.8	55.5	48.0	42.6
28	49.9	51.4	52.9	53.4	53.9	47.6	42.2
30		46.8	50.0	49.0	48.0	45.8	41.9
32		42.8	44.6	44.9	43.2	43.1	41.2
34		38.4	40.0	42.2	41.2	41.2	38.0
36			36.9	37.7	37.1	36.5	35.3
38			32.9	34.4	35.9	34.3	32.8
40				31.5	33.3	31.8	30.7
42				28.2	29.3	30.6	28.7
44				25.2	26.9	29.6	27.0
46					24.4	25.5	25.5
48					22.4	23.4	23.8
50					20.2	21.5	22.7
52						19.6	20.5
54						18.1	18.8
56						16.3	17.3
58							16.1
60							14.6
64							

Notes:

1. For boom sections, fixed jib rear pendant needs to be removed; for boom tapered section, tower jib guide pulley needs to be installed.
2. For boom raising, position crawler drive sprocket at the rear of the crane, it is recommended to use auxiliary crane or wedge block to assist boom raising.

Tower jib working condition _ tower jib main hook lifting capacity table (without boom pulley block and tower jib single top, HW/1_85°_125t+40t_40m)

Boom length (m) HW/1	40						
	Tower jib length (m)						
	24	30	36	42	48	54	60
Radius (m)	t	t	t	t	t	t	t
14	113.0						
15	105.4	94.5					
16	100.9	94.0					
17	94.6	90.4	78.5				
18	91.6	88.2	78.1				
19	83.9	85.3	77.8	66.6			
20	79.8	78.4	76.6	66.0	55.9		
22	71.5	71.1	71.3	65.3	55.4	46.8	
24	62.4	64.0	64.7	63.3	55.1	46.6	40.5
26	56.3	57.8	57.4	56.8	54.1	46.5	40.4
28	49.9	51.1	52.9	52.9	51.4	46.3	40.3
30		46.8	50.0	49.0	47.5	45.0	40.2
32		42.8	44.6	44.9	43.2	41.5	40.0
34		38.4	40.0	42.2	40.7	39.1	37.8
36			36.9	37.7	37.1	36.5	35.1
38			32.9	34.4	35.9	34.3	32.6
40			28.9	31.5	33.3	31.8	30.5
42				28.2	29.3	30.6	28.5
44				25.2	26.9	29.6	26.9
46					21.7	24.4	25.5
48					22.4	23.4	23.8
50					20.2	21.5	22.7
52						19.6	20.5
54						18.1	18.8
56						16.3	17.3
58							16.1
60							14.6
64							

Notes:

1. For boom sections, fixed jib rear pendant needs to be removed; for boom tapered section, tower jib guide pulley needs to be installed.
2. For boom raising, position crawler drive sprocket at the rear of the crane, it is recommended to use auxiliary crane or wedge block to assist boom raising.

Tower jib working condition

Tower jib working condition _ tower jib main hook lifting capacity table (without boom pulley block and tower jib single top, HW/1_85°_125t+40t_46m)

Boom length (m) HW/1	46						
	Tower jib length (m)						
	24	30	36	42	48	54	60
Radius (m)	t	t	t	t	t	t	t
14	110.0						
15	102.0						
16	97.8	90.2					
17	94.6	89.2	75.0				
18	91.6	88.2	75.5				
19	83.3	85.3	75.0	63.7			
20	77.2	75.7	74.8	63.2	53.5		
22	67.4	69.6	70.7	62.5	53.9	44.6	
24	61.1	63.7	64.7	58.8	53.4	44.4	38.6
26	55.7	57.1	57.0	56.8	52.6	44.2	38.5
28	49.9	50.7	52.0	52.9	51.4	44.0	38.5
30		46.6	48.0	48.0	47.5	43.5	38.4
32		42.8	43.4	44.9	43.2	41.2	38.1
34		38.4	40.0	42.2	40.7	38.0	36.4
36			36.9	36.9	37.1	36.5	34.5
38			32.9	34.4	35.9	34.3	32.3
40			28.9	31.5	33.3	31.8	30.3
42				28.2	29.3	30.6	28.3
44				25.2	26.9	29.6	26.6
46				21.7	24.4	25.5	25.5
48					22.4	23.4	23.8
50					20.2	21.5	22.7
52					18.1	19.6	20.5
54						18.1	18.8
56						16.3	17.3
58							16.1
60							14.6
64							

Notes:

1. For boom sections, fixed jib rear pendant needs to be removed; for boom tapered section, tower jib guide pulley needs to be installed.
2. For boom raising, position crawler drive sprocket at the rear of the crane, it is recommended to use auxiliary crane or wedge block to assist boom raising.

Tower jib working condition _ tower jib main hook lifting capacity table (without boom pulley block and tower jib single top, HW/1_85°_125t+40t_52m)

Boom length (m) HW/1	52						
	Tower jib length (m)						
	24	30	36	42	48	54	60
Radius (m)	t	t	t	t	t	t	t
15	98.5						
16	95.6	85.0					
17	92.6	84.7					
18	86.4	82.1	71.5				
19	80.7	79.9	71.1	60.0			
20	77.2	74.8	70.6	59.9			
22	64.4	66.7	67.3	59.6	50.6	42.1	
24	58.3	61.7	61.3	56.6	50.3	42.1	37.2
26	53.1	57.1	57.0	52.9	49.5	41.8	36.8
28	48.7	49.0	52.0	50.5	48.1	41.7	36.5
30		44.6	48.0	48.0	47.5	40.3	36.4
32		41.4	41.2	44.9	42.1	38.6	35.2
34		38.4	38.1	42.2	40.2	36.9	33.6
36			35.5	35.4	37.1	35.2	31.9
38			32.1	32.8	35.2	32.3	29.9
40			28.9	29.7	33.3	31.5	28.0
42				27.0	27.3	30.6	26.3
44				24.7	25.2	29.6	25.6
46				22.6	23.1	23.2	24.7
48					21.4	21.6	23.8
50					19.7	20.0	22.7
52					18.1	18.5	18.7
54						17.2	17.4
56						16.0	16.3
58						14.7	15.2
60							14.2
64							

Notes:

1. For boom sections, fixed jib rear pendant needs to be removed; for boom tapered section, tower jib guide pulley needs to be installed.
2. For boom raising, position crawler drive sprocket at the rear of the crane, it is recommended to use auxiliary crane or wedge block to assist boom raising.

Tower jib working condition

Tower jib working condition _ tower jib main hook lifting capacity table (without boom pulley block and tower jib single top, HW/1_85°_125t+40t_58m)

Boom length (m) HW/1	58						
	Tower jib length (m)						
	24	30	36	42	48	54	60
Radius (m)	t	t	t	t	t	t	t
15	95.2						
16	89.3						
17	83.2	79.6					
18	79.4	77.2					
19	74.6	72.5	66.8				
20	70.3	68.3	66.4	56.9			
22	63.7	63.7	63.4	56.4	47.0		
24	55.9	56.8	56.4	55.4	46.7	41.2	
26	51.0	52.9	52.9	52.9	46.4	41.2	34.8
28	46.7	48.0	47.0	46.6	46.0	40.3	34.3
30	43.1	42.6	43.1	42.8	42.8	38.7	34.2
32		39.5	39.9	40.2	40.3	36.5	32.7
34		36.5	36.4	36.3	37.2	34.4	31.4
36		32.8	33.3	34.3	34.3	33.1	29.4
38			31.4	32.4	33.3	32.3	27.6
40			27.4	27.7	28.6	27.9	26.5
42			24.4	25.4	26.0	25.1	24.8
44				23.2	23.5	23.3	23.3
46				21.3	21.7	21.7	21.8
48					20.0	20.3	20.0
50					18.4	18.6	18.7
52					17.1	17.2	17.3
54						16.1	16.3
56						14.9	15.2
58						13.8	14.1
60							13.2
64							11.5
68							

Notes:

1. For boom sections, fixed jib rear pendant needs to be removed; for boom tapered section, tower jib guide pulley needs to be installed.
2. For boom raising, position crawler drive sprocket at the rear of the crane, it is recommended to use auxiliary crane or wedge block to assist boom raising.

Tower jib working condition _ tower jib main hook lifting capacity table (without boom pulley block and tower jib single top, HW/1_85°_125t+40t_64m)

Boom length (m) HW/1	64						
	Tower jib length (m)						
	24	30	36	42	48	54	60
Radius (m)	t	t	t	t	t	t	t
16	85.6						
17	81.2	72.9					
18	76.0	71.9					
19	71.3	70.6	61.5				
20	67.2	66.5	60.9	52.2			
22	59.7	59.6	58.2	51.6	44.3		
24	54.0	53.8	53.4	49.8	43.9	37.5	
26	49.1	48.6	48.6	46.6	42.9	37.3	32.8
28	45.1	44.5	44.6	43.2	40.3	37.0	32.6
30	41.6	41.1	41.1	39.9	37.7	35.0	32.3
32		37.9	37.5	36.8	35.2	33.0	30.7
34		34.3	34.2	33.8	32.7	30.9	29.1
36		30.9	31.1	30.8	30.3	28.9	27.6
38			28.4	28.3	28.1	27.1	26.0
40			25.8	25.9	25.7	25.3	24.4
42			23.4	23.7	23.7	23.5	22.8
44				21.8	21.9	21.6	21.4
46				20.0	20.2	20.1	20.0
48					18.7	18.6	18.5
50					17.2	17.3	17.2
52					16.0	16.1	16.2
54						15.0	15.1
56						13.9	14.0
58						12.9	13.1
60							12.2
64							10.6
68							

Notes:

1. For boom sections, fixed jib rear pendant needs to be removed; for boom tapered section, tower jib guide pulley needs to be installed.
2. For boom raising, position crawler drive sprocket at the rear of the crane, it is recommended to use auxiliary crane or wedge block to assist boom raising.

Tower jib working condition

Tower jib working condition tower jib single top the third hook (without boom pulley block, with tower jib main hook, HWS/3)

Tower jib working condition_tower jib single top the third hook working range (without boom pulley block, with tower jib main hook, HWS/3)

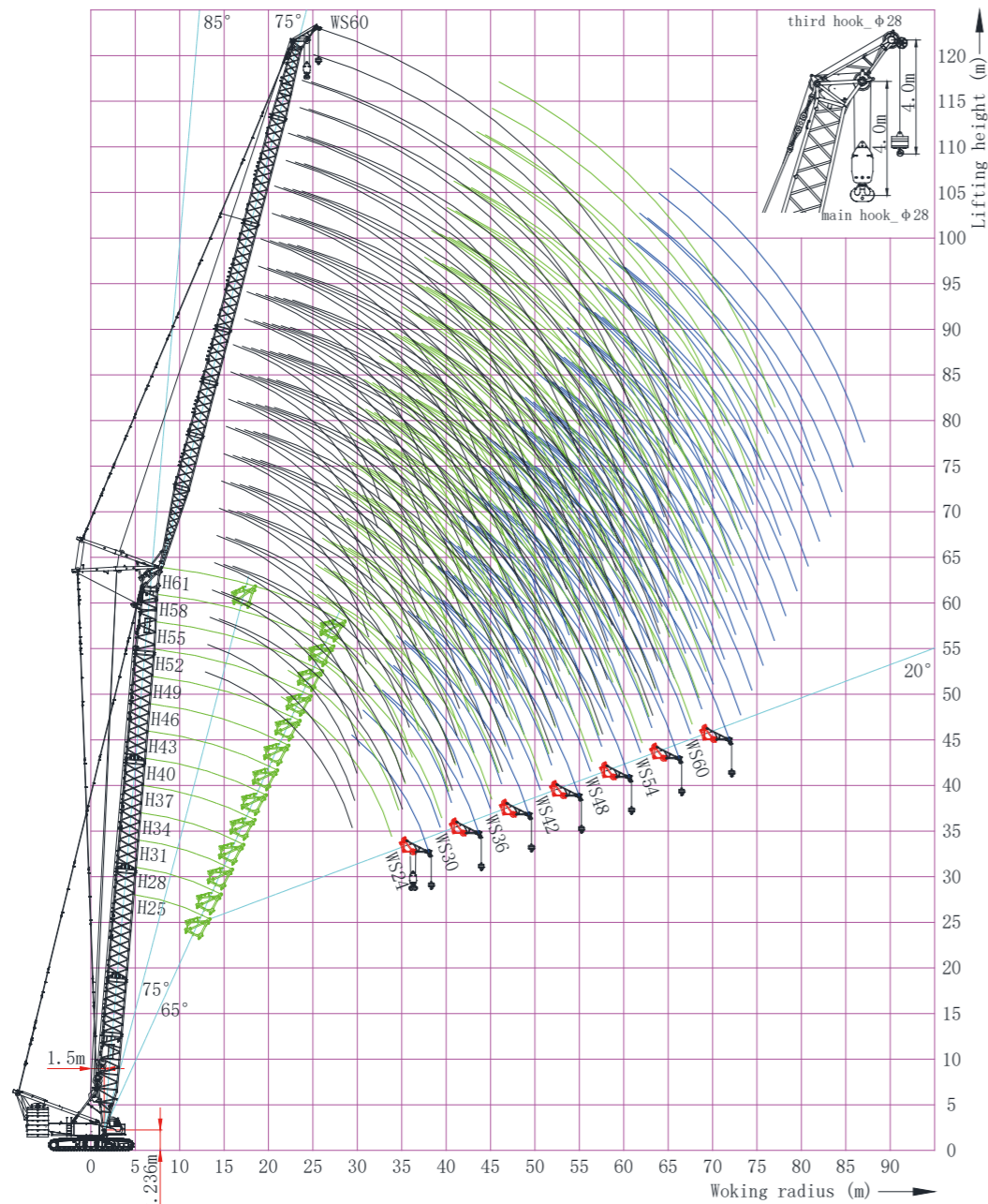

Tower jib working condition_tower jib single top third hook range (without boom pulley block, with tower jib main hook, HWS/3)

Tower jib working condition _ Tower jib single top the third hook lifting capacity table (without boom pulley block, with tower jib main hook, HWS/3_85°_125t+40t_61m)

Boom length (m) HWS/3	61 Tower jib length (m)						
	24	30	36	42	48	54	60
Radius (m)	t	t	t	t	t	t	t
18	16.0						
19	16.0	16.0					
20	16.0	16.0					
22	16.0	16.0	16.0	16.0			
24	16.0	16.0	16.0	16.0	16.0		
26	16.0	16.0	16.0	16.0	16.0	16.0	
28	16.0	16.0	16.0	16.0	16.0	16.0	16.0
30	16.0	16.0	16.0	16.0	16.0	16.0	16.0
32		16.0	16.0	16.0	16.0	16.0	16.0
34		16.0	16.0	16.0	16.0	16.0	16.0
36		16.0	16.0	16.0	16.0	16.0	16.0
38			16.0	16.0	16.0	16.0	16.0
40			16.0	16.0	16.0	16.0	16.0
42			16.0	16.0	16.0	16.0	16.0
44				16.0	16.0	16.0	16.0
46				16.0	16.0	16.0	16.0
48					15.8	16.0	16.0
50					13.9	14.2	14.7
52					12.9	12.9	13.0
54						11.7	11.8
56						10.6	10.8
58						9.5	9.8
60							8.9
64							7.2
68							

Notes:

1. For boom sections, fixed jib rear pendant needs to be removed; for boom tapered section, tower jib guide pulley needs to be installed.
2. For boom raising, position crawler drive sprocket at the rear of the crane, it is recommended to use auxiliary crane or wedge block to assist boom raising.

Tower jib working condition

Tower jib working condition_tower jib main hook (without boom pulley block, with tower jib single top the third hook, HWS/1)

Tower jib working condition_tower jib main hook working range (without boom pulley block, with tower jib single top the third hook, HWS/1)

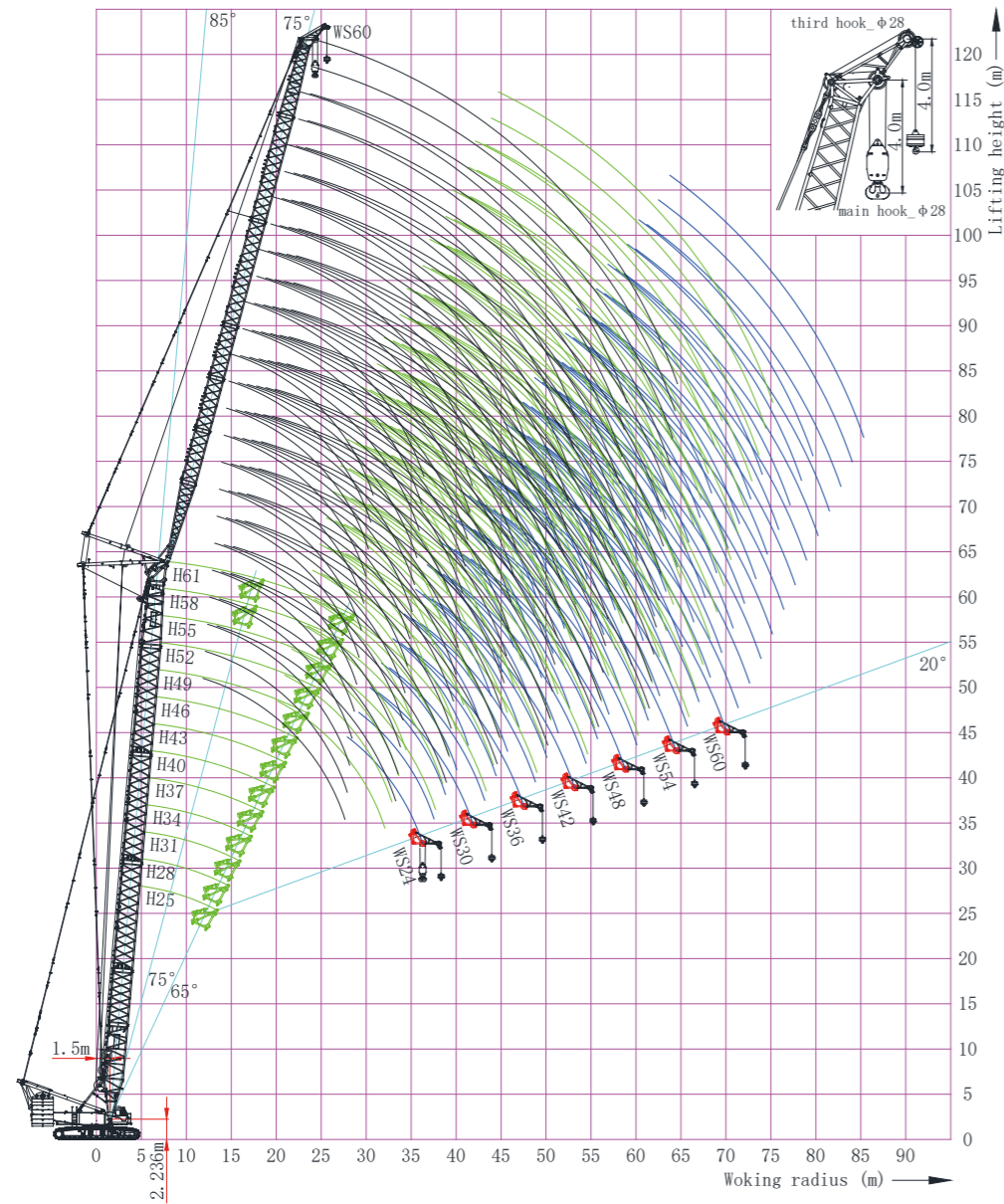

Tower jib working condition_tower jib main hook range
(without boom pulley block, with tower jib single top the third hook, HWS/1)

Tower jib working condition_tower jib main hook lifting capacity table (without boom pulley block, with tower jib single top the third hook, HWS/1_85°_125t+40t_61m)

Boom length (m) HWS/3	61 Tower jib length (m)						
	24	30	36	42	48	54	60
Radius (m)	t	t	t	t	t	t	t
16	84.1						
17	78.2	72.6					
18	76.0	71.7					
19	71.3	67.7	63.3				
20	67.0	63.6	63.1	53.6			
22	60.4	60.4	60.1	53.2	43.7		
24	51.5	54.7	53.1	52.1	43.8	38.7	
26	47.7	49.7	49.7	49.7	43.1	38.7	34.7
28	42.5	44.8	44.8	43.8	42.7	37.0	32.8
30	39.0	38.9	39.9	39.6	39.6	36.0	30.6
32		35.9	36.6	37.0	37.1	33.2	29.3
34		32.5	32.5	33.1	34.0	31.2	28.2
36		29.0	30.1	31.1	31.1	29.9	25.6
38			28.2	29.2	30.6	29.2	24.0
40			23.7	24.3	25.4	24.8	23.3
42			21.3	21.7	22.8	22.3	21.8
44				19.6	20.1	20.2	20.1
46				17.7	18.2	18.5	18.7
48					16.6	17.1	16.8
50					14.7	15.0	15.5
52					13.7	13.7	13.8
54						12.5	12.6
56						11.4	11.6
58						10.3	10.6
60							9.7
64							8.1
68							

Notes:

1. For boom sections, fixed jib rear pendant needs to be removed; for boom tapered section, tower jib guide pulley needs to be installed.
2. For boom raising, position crawler drive sprocket at the rear of the crane, it is recommended to use auxiliary crane or wedge block to assist boom raising.

Main components

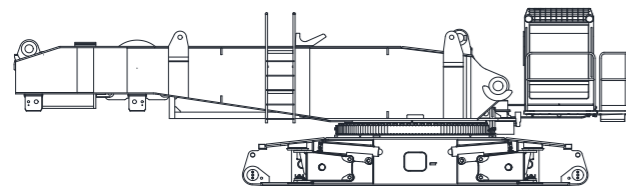

Basic machine transport plan A ×1	
Length (L)	11120mm
Width (W)	3000mm
Height (H)	3300mm
Weight (W)	36200kg

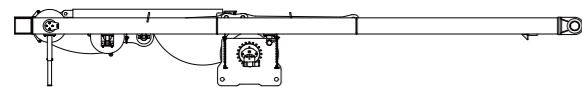

Mast transport parts ×1	
Length (L)	10300mm
Width (W)	2200mm
Height (H)	1420mm
Weight (W)	7500kg

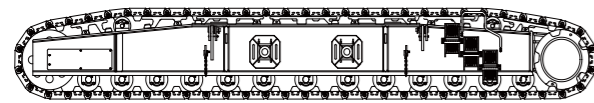

Left track frame ×1	
Length (L)	9550mm
Width (W)	1450mm
Height (H)	1350mm
Weight (W)	23400kg

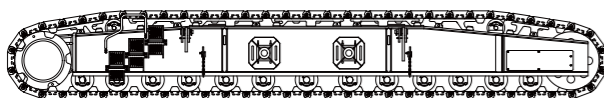

Right track frame ×1	
Length (L)	9550mm
Width (W)	1450mm
Height (H)	1350mm
Weight (W)	23400kg

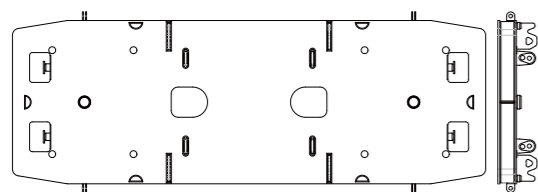

Turntable counterweight tray ×1	
Length (L)	6900mm
Width (W)	2630mm
Height (H)	570mm
Weight (W)	20000kg

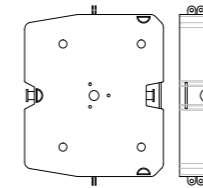

Turntable counterweight slab I ×8	
Length (L)	2100mm
Width (W)	2630mm
Height (H)	580mm
Weight (W)	10000kg

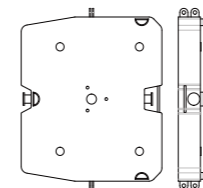

Turntable counterweight slab II ×4	
Length (L)	2100mm
Width (W)	2630mm
Height (H)	400mm
Weight (W)	5000kg

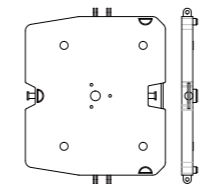

Turntable counterweight slab III ×2	
Length (L)	2100mm
Width (W)	2630mm
Height (H)	240mm
Weight (W)	2500kg

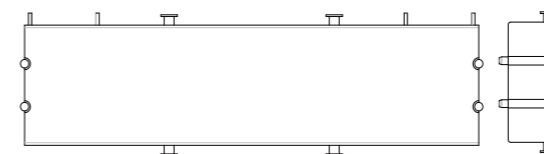

Car-body counterweight slab I ×2	
Length (L)	5600mm
Width (W)	1630mm
Height (H)	720mm
Weight (W)	15000kg



Car-body counterweight slab II ×2	
Length (L)	5600mm
Width (W)	1620mm
Height (H)	170mm
Weight (W)	5000kg

Main components

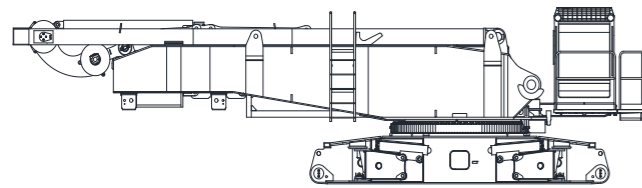

Basic machine transport plan B	×1
Length (L)	13200mm
Width (W)	3000mm
Height (H)	3320mm
Weight (W)	45600kg

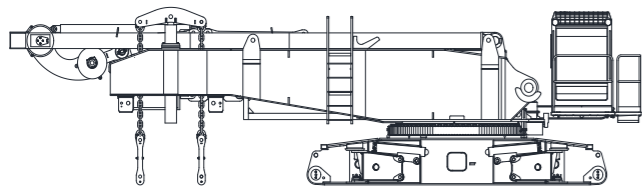

Basic machine transport plan C	×1
Length (L)	13200mm
Width (W)	3000mm
Height (H)	3320mm
Weight (W)	45600kg

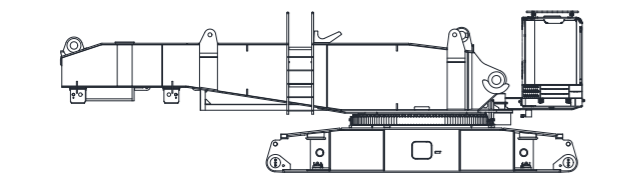

Basic machine transport plan D	×1
Length (L)	10600mm
Width (W)	3000mm
Height (H)	3400mm
Weight (W)	35200kg

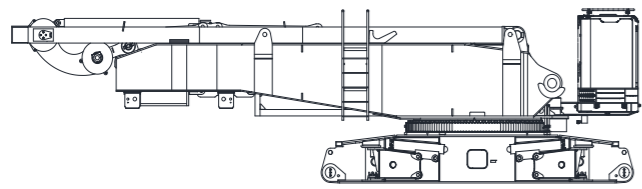

Basic machine transport plan E	×1
Length (L)	12600mm
Width (W)	3000mm
Height (H)	3400mm
Weight (W)	45000kg

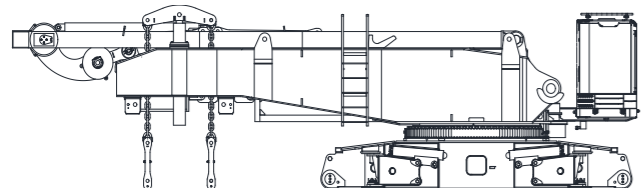

Basic machine transport plan F	×1
Length (L)	12600mm
Width (W)	3000mm
Height (H)	3400mm
Weight (W)	46500kg

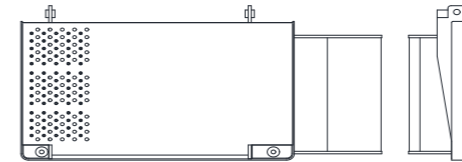

Catwalk I	×1
Length (L)	1176mm
Width (W)	612mm
Height (H)	218mm
Weight (W)	32kg

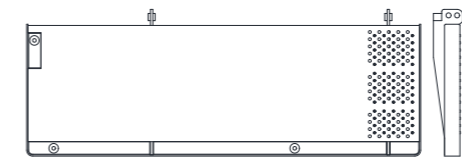

Catwalk II	×1
Length (L)	1665mm
Width (W)	612mm
Height (H)	125mm
Weight (W)	47kg

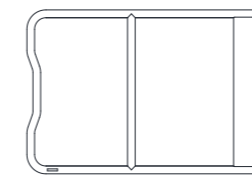

Guard rail I	×1
Length (L)	1182mm
Width (W)	109mm
Height (H)	805mm
Weight (W)	12kg

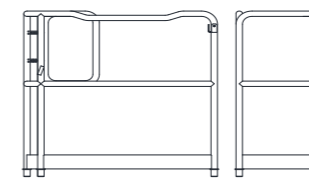

Guard rail II	×1
Length (L)	1138mm
Width (W)	539mm
Height (H)	1mm
Weight (W)	12kg

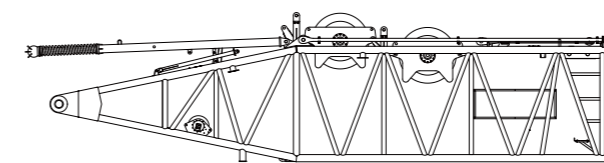

Boom butt	×1
Length (L)	11250mm
Width (W)	2770mm
Height (H)	2900mm
Weight (W)	14930kg

Main components

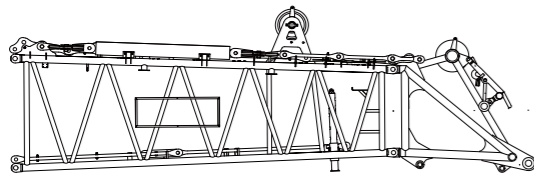

Boom tapered section and connection	×1
Length (L)	9760mm
Width (W)	2770mm
Height (H)	3200mm
Weight (W)	6890kg

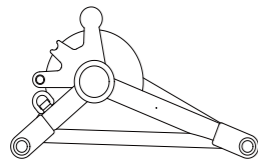

Boom sheave block(260t)	×1
Length (L)	1680mm
Width (W)	1350mm
Height (H)	960mm
Weight (W)	1150kg

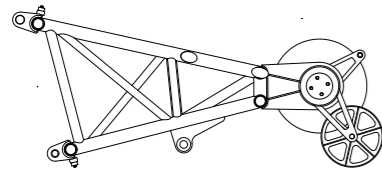

Boom single top sheave	×1
Length (L)	2400mm
Width (W)	1200mm
Height (H)	1050mm
Weight (W)	400kg

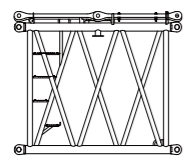

Boom 3m insert	×1
Length (L)	3180mm
Width (W)	2770mm
Height (H)	2450mm
Weight (W)	1370kg

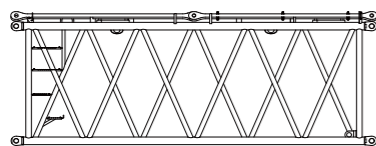

Boom 6m insert	×1
Length (L)	6180mm
Width (W)	2770mm
Height (H)	2450mm
Weight (W)	2260t

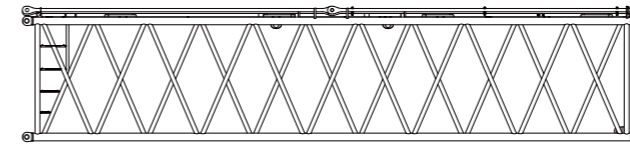

Boom 12mA insert	×3
Length (L)	12180mm
Width (W)	2770mm
Height (H)	2450mm
Weight (W)	4180kg

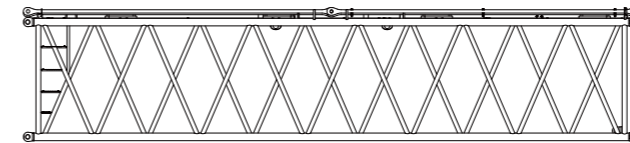

Boom 12mB insert	×2
Length (L)	12180mm
Width (W)	2770mm
Height (H)	2450mm
Weight (W)	3650kg

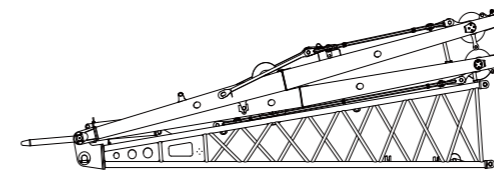

Tower jib set	×1
Length (L)	10810mm
Width (W)	2780mm
Height (H)	3190mm
Weight (W)	7200kg

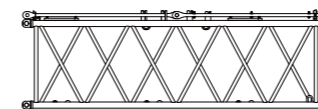

Tower jib 6mA insert	×1
Length (L)	6180mm
Width (W)	2150mm
Height (H)	1950mm
Weight (W)	1360kg

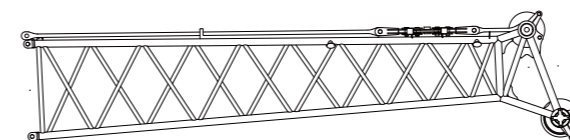

Tower jib top	×1
Length (L)	9570mm
Width (W)	2150mm
Height (H)	2250mm
Weight (W)	2880kg

Main components

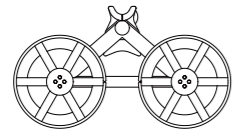

Trolley	×1
Length (L)	1250mm
Width (W)	1150mm
Height (H)	700mm
Weight (W)	400kg

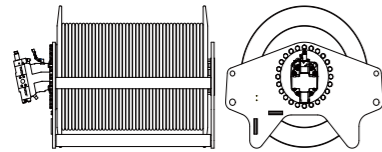

Main hoist winch II(optional, tower jib single top)	×1
Length (L)	1250mm
Width (W)	1150mm
Height (H)	700mm
Weight (W)	4100kg

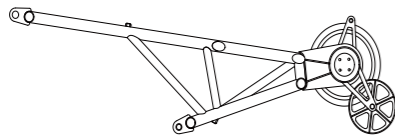

Tower jib single top (optional)	×1
Length (L)	3300mm
Width (W)	900mm
Height (H)	950mm
Weight (W)	500kg

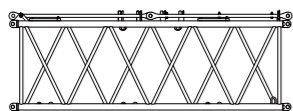

Tower jib 6mB insert	×2
Length (L)	6180mm
Width (W)	2150mm
Height (H)	1950mm
Weight (W)	1150kg

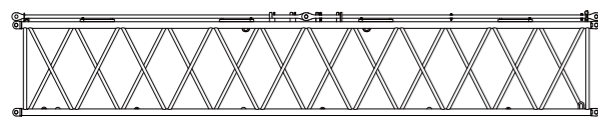

Tower jib 12m insert	×2
Length (L)	12180mm
Width (W)	2150mm
Height (H)	1950mm
Weight (W)	1980kg

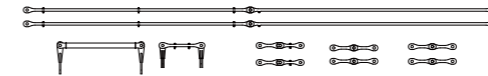

Additional pendant assy. (optional)	×1
Length (L)	6180mm
Width (W)	800mm
Height (H)	300mm
Weight (W)	1500kg

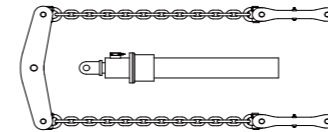

Turntable counterweight self-assembly / disassembly assy. (optional)	×2
Length (L)	4500mm
Width (W)	590mm
Height (H)	400mm
Weight (W)	400kg



Turntable counterweight locking chain assy.	×2
Length (L)	3800mm
Width (W)	470mm
Height (H)	470mm
Weight (W)	400kg

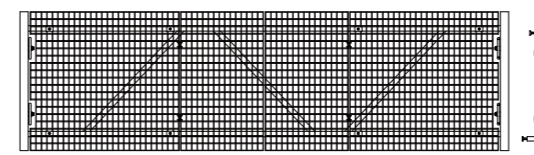

Undercarriage catwalk	×2
Length (L)	3560mm
Width (W)	950mm
Height (H)	200mm
Weight (W)	200kg

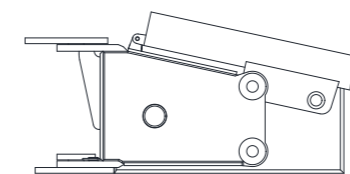

Left/right outriggers and outrigger cylinder	×4
Length (L)	1800mm
Width (W)	950mm
Height (H)	250mm
Weight (W)	350kg

Main components

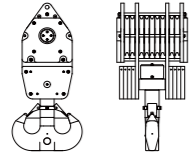

260t hook block assy.	×1
Length (L)	1070mm
Width (W)	1070mm
Height (H)	2350mm
Weight (W)	4200kg

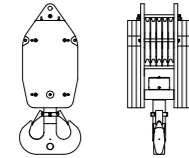

160t hook block assy.	×1
Length (L)	850mm
Width (W)	870mm
Height (H)	2120mm
Weight (W)	3900kg

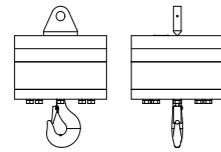

16t hook block assy.	×1
Length (L)	600mm
Width (W)	600mm
Height (H)	870mm
Weight (W)	900kg

Note:

- 1.The parts which are not listed above include clips, small size pin shafts, bolts, several small pendants or sling connectors, and etc., total weight is not more than 3t.
- 2.Slight difference is ineluctable during product manufacture, and dimension and weight of some parts are variable due to continuous improvement in products.
- 3.Various pendants are easy confused, so before transportation, customers should make marks on corresponding pendants to avoid unnecessary troubles.

